

# Effect of charge accumulated at oil–paper interface on parameters considered for power transformer insulation diagnosis

ISSN 1751-8822  
Received on 24th July 2017  
Revised 11th December 2017  
Accepted on 30th December 2017  
E-First on 5th February 2018  
doi: 10.1049/iet-smt.2017.0354  
www.ietdl.org

Deepak Mishra<sup>1</sup> ✉, Nasirul Haque<sup>2</sup>, Arijit Baral<sup>1</sup>, Sivaji Chakravorti<sup>2</sup>

<sup>1</sup>Department of Electrical Engineering, IIT (ISM), Dhanbad, Jharkhand, India

<sup>2</sup>Department of Electrical Engineering, Jadavpur University, Kolkata, West Bengal, India

✉ E-mail: deepak2010urs@gmail.com

**Abstract:** Polarisation and depolarisation current (PDC) measurement and analysis is one of the popular tools for effective diagnosis of power transformer insulation. Normally, it is assumed that polarisation current is the combination of the current due to dipole movement and conduction current. Similarly, the depolarisation current is only due to the relaxation of dipoles. However, it is found that after eliminating the effect of dc conduction from polarisation current the resulting current is not similar to that of measured depolarisation current. This shows some non-linearity is present in the system. This non-linearity occurs due to movement of trapped charge that resides in the interfacial region of oil–paper insulation. This study shows the effect of de-trapping charge on various performance parameters that are used for insulation diagnosis like paper moisture and dielectric dissipation factor ( $\tan\delta$ ).

## 1 Introduction

In the case of power transformers, oil impregnated paper is considered as the insulation of choice. Parameters like %paper moisture or %pm,  $\tan\delta$  and the peak value of return voltage spectrum are commonly monitored by utilities for transformer insulation diagnosis purposes. These parameters are usually evaluated from the dielectric response of the insulation concerned. There are different time domain methods available for analysis of dielectric response out of which polarisation and depolarisation current (PDC) and return voltage measurement are popular among utilities [1–5].

According to available literature, polarisation current is composed of two components, one is the charging current due to the alignment of dipoles and the other is conduction current. On the other hand, the de-polarisation current is assumed to be only due to the relaxation of polarised dipoles, as there is no conduction phenomenon in this case [6]. In most of the cases, analysis of PDC is done by using classical Debye model (CDM). This model consists of several branches of  $R$ ,  $C$  network connected in parallel. One of the major drawbacks of CDM is that it considers the dielectric as a linear model [1–3]. In linear modelling it is assumed that PDC data is the result of only dipolar and conduction current contribution.

According to the linear dielectric theory if the conduction current is identified accurately and subtracted from the polarisation current, then magnitude of this resulted current should be equal to the depolarisation current. However, practically significant difference occurs between resulting current and depolarisation current. This shows that there is some non-linearity present in the system. The main reason behind this non-linearity is accumulation

of space charge on the interfacial region of oil–paper insulation. Available literature shows that conductivity difference between oil and paper is the primary reason behind accumulation of space charge at the interface [6–11]. During depolarisation period, there is a high possibility that a part of this accumulated charges moves towards the electrodes and gets absorbed. This in turn produces a current known as de-trapping current. In that case it will produce a current. This current, which is only due to the ion absorption by electrodes during depolarisation process, is difficult to separate from the dipole current using conventional dielectric model.

It is worth mentioning here that ageing of insulation does have an effect on the magnitude of de-trapped charge as it leads to degradation of cellulose surface [11–13] and generation of ionic ageing by-products. By using numerical integration, the de-trapped charge can be obtained from the de-trapping current. It should be remembered that trapping of charge happens at the interface of oil and paper. Hence, it is obvious that the magnitude of trapped charge for a given unit will be sensitive to its insulation geometry. Furthermore, it is practically difficult to ensure that all power transformers analysed will have identical physical dimensions. The influence of insulation geometry on de-trapped charge magnitude can be reduced by normalising it by a parameter that is also influenced by insulation dimensions. In the present work, the de-trapping charge obtained from different real-life power transformers are normalised by their respective dc insulation resistance. In this paper, the effect of normalised de-trapping charge on paper moisture and the peak value of return voltage spectrum is investigated. Aforementioned analysis is carried out on several real-life power transformers whose details are provided in Table 1.

## 2 CDM for oil–paper insulation

Available literature shows that modelling of PDC current and hence the behaviour of insulation is possible using the simple  $R$ – $C$  network. Researchers have reported many such networks for modelling the response function of insulation. Perhaps the most popular among them is the CDM [3]. CDM consists of a parallel combination of series  $R$ ,  $C$  element. In this model, the insulation is considered as a *black box* and the depolarisation current is approximated by an equivalent circuit consisting of several  $R$ ,  $C$  branches. Each  $R$ ,  $C$  branch corresponds to a specific group of dipoles in the insulation. These randomly oriented groups are

**Table 1** Details of transformer

Transformer name	Power rating	Age, years
Trafo1	240 MVA/420 kV	36
Trafo2	200 MVA/420 kV	33
Trafo3	240 MVA/400 kV	34
Trafo4	200 MVA/400 kV	17
Trafo5	200 MVA/400 kV	32
Trafo6	200 MVA/420 kV	15
Trafo7	240 MVA/420 kV	34

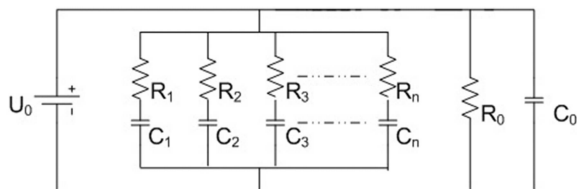

**Fig. 1** Structure of CDM

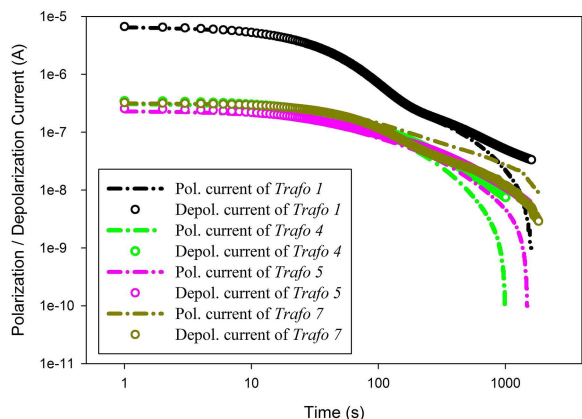

**Fig. 2** Polarisation (without dc conductivity) and de-polarisation current for transformer under testing

represented by branches of CDM and have associated time constant given by  $\tau_i = R_i C_i$ . The major advantage of this method is that it does not require the information regarding the geometry of insulation. The equivalent Debye model is shown in Fig. 1.

When the charging voltage is applied across the dielectric then dipole present in it aligns in the direction of the applied electric field. In this case, the movement of dipoles contributes to polarisation current. After a certain time, the dielectric is shorted then dipoles start relaxing towards their original positions. This movement of dipoles constitutes depolarisation current. Here  $U_0$  represents the dc charging voltage applied during the polarisation phase. The different branches  $R_1 C_1, R_2 C_2 \dots R_n C_n$  in Fig. 1 represent different dipole groups which have different relaxation times. The value of  $R_0$  and  $C_0$  depicts dc insulation resistance and geometric capacitance, respectively.

The discussion presented above suggests that the formulation of CDM is based on the assumption that polarisation current  $i_{pol}$  is constituted by two components: one is obtained from the movement of dipoles called dipole current and other one is conduction current  $i_{cond}$  (as shown by (1)). While de-polarisation current is composed of only the contribution of the dipoles relaxation (as shown by (2))

$$i_{pol} = i_{p(dipole)} + i_{(cond.)} \quad (1)$$

$$i_{depol} = i_{d(dipole)} \quad (2)$$

where  $i_{p(dipole)}$  and  $i_{d(dipole)}$  are the dipole current contribution in polarisation and depolarisation current, respectively.

Assumptions mentioned above are practically difficult to ensure. In order to illustrate this fact, Fig. 2 shows the plot of polarisation current (without the influence of dc conduction) and de-polarisation current for four transformers Trafo1, Trafo4, Trafo5 and Trafo7.

The dc conduction current can be easily computed using the steady-state values of PDC data [3]. In order to obtain Fig. 2, the dc conduction current is calculated first and then subtracted from the measured polarisation current. It can be observed from Fig. 2 that there exists a deviation between polarisation current (without the influence of dc conduction) and de-polarisation current. The degree of deviation due to de-trapping current is found to be different for different transformers symbolising that the magnitude of the de-trapping current is different for each transformer.

### 3 Calculation of de-trapping charge

In presence of an electric field, charges are introduced in a dielectric in two possible ways: (i) ionisation and (ii) charge injection from electrodes. Available literatures [4] show that, in presence of fields having low magnitude, certain compounds in mineral oil and cellulose material (like pressboard) become easily ionised. These ions are known to gradually migrate from positive to negative electrode, producing conduction current. Researchers have also reported that cellulose layer acts as barrier for positive charge. It is a known fact that the oil–paper interface consists (at microscopic level) of large amount of chain folds and broken bonds. Compared to negative charge, the less mobile positive charges get easily trapped in these broken bonds and chain folds region [9, 13–15]. Consequently, the interface region behaves like a potential barrier, where the positive charges get trapped. This process continues until the trapped charges obtain sufficient energy to cross the barrier and contribute to the conduction process again. In the case of transformer insulation, several alternate layers of oil and paper exist which create a large interface region. Other factors like difference between conductivity of oil and cellulose, presence of moisture and ageing also influence interfacial charge trapping [7, 9, 15, 16]. In fact, the trapping process can be assumed to be a form of energy storage in which charge build-up process is confined to specific sites. The energy required by a trapped carrier to overcome the interfacial potential barrier to affect the overall electrical conduction process is called trap depth or trap energy [16, 17]. The trapped charges can acquire this energy through several processes including thermal collisions, photon bombardment and electric field [18, 19]. The process of acquiring necessary trap energy by a bound carrier to get released is known as de-trapping. Depending on the required trap depth, the trapped carrier may stay bound for several hours to few days. This in turn results into localised field enhancement. It is understood that these trapped charge centres eventually lowers the reaction activation barrier and accelerates the degradation of oil–paper composite insulation [20].

Classical two potential well model is used to explain the ionic conduction process in a typical solid–liquid dielectric system [11, 12]. According to this model, ionic conduction is possible when ion moves one trap site to other. Let us consider  $P$  and  $Q$  are the two trapping sites, separated by a distance of  $2l$  and barrier energy of  $\Delta H$ . If  $E_0$  is the applied electric field in the direction of ion well  $P$  to  $Q$  [10] then ion situated at location  $P$  requires  $(\Delta H - e l E_0)$  amount of energy to move at site  $Q$ , where,  $e$  is the charge of the ion. Similarly, an ion located in site  $Q$  will require energy of  $(\Delta H + e l E_0)$  to jump to site  $P$ . In the absence of any external field, the probability  $\Lambda$  of ion movement from  $P$  to  $Q$  or vice versa is given by

$$\Lambda = \nu \exp\left[-\frac{\Delta H}{kT}\right] \quad (3)$$

where  $\nu$  is the vibration frequency (number of attempted ion jumps per unit time),  $k$  is Boltzmann's constant ( $1.38 \times 10^{23}$ ) and  $T$  is temperature. The value of  $\nu$  typically lies within the range of  $10^{11}$ – $10^{12}$  [13]. The relaxation time of this process  $\Gamma$  is defined as

$$\Gamma = \frac{1}{2\Lambda} \quad (4)$$

Depending on the required trapping energy, the trapped charge can take long time (in hours or days) to de-trap. In CDM, it is considered that the PDC carries only dipolar movement and charge conduction. The ions movement is basically responsible for the conduction current part in polarisation current. Due to the difference in the conductivity of oil and paper, a large number of ions are gathered at the interfacial region of oil–paper insulation. During depolarisation phase, this interfacial charge slowly de-trapped and moves towards electrode and absorbed. This produces a current, which contributes in the de-polarisation current. Present work makes an attempt to identify this component from PDC

measurements. In order to do so, following assumptions have been taken:

- i. There is no injection of charge during polarisation process in the dielectric medium from electrodes.
- ii. The insulation system consists of several types of dipoles, i.e. polar compounds present in oil and cellulose, water dipoles and so on. These dipoles vary according to their relaxation characteristics. Each group of dipole behaves linearly in the dielectric polarisation and depolarisation processes. It implies, the time required to orient a particular group of dipoles under electric stress is same of the time it takes to relax to its initial condition during short-circuit (depolarisation) conditions.

Impurities present in insulation results in the formation of deep traps [17]. However, the density of deep traps is much lesser compared to shallow traps [17, 18]. In a well-prepared un-aged insulation, the impurities are expected to be very small and negligible. With ageing, new traps are generated in insulation which is mainly shallow in nature [21–24]. A comparison of space charge in un-aged specimen and specimens aged at different stages in [23] showed that the proportion of charge accumulation due to ageing is much higher in aged specimens when compared to un-aged one. Therefore, it can be opined that the contribution of the space charge created by the impurities present in insulation is small compared to the component created by ageing and various chemical reactions.

The polarisation current decays rapidly with time just after applying a dc voltage until a steady-state current is reached after about a time  $t_c$ . The discharging current is a mirror of charge current reduced by the steady-state current notably under low fields and low temperatures. However, the discharging current has at least two components: the first is determined by depolarisation current and the second is determined by the drift of the total space charge present in the polymer [25, 26]. Under the application of low electric field there is very rare chance of charge injection from the electrode to insulation. However, during polarisation phase ionisation phenomenon is very active. It has been observed that aged transformer not only has different types of acidic component which can be ionised easily under the application of electric field but also contains a large amount of moisture content in insulation [6–13, 20, 21, 27]. If the charging and discharging time is same then the polarisation current due to specific dipole group is same as relaxation current of that dipole group. In such situation if the conduction current is calculated accurately and subtracted from original measured polarisation current, then this resultant current is almost similar to that relaxation current due to the dipole. So depolarisation current is represented as

$$i_{\text{depol}} = i_{\text{d(dipole)}} + i_{\text{(de-trap)}} \quad (5)$$

where  $i_{\text{d(dipole)}}$  is dipole current and  $i_{\text{(de-trap)}}$  is de-trapping current contribution in depolarisation current.

It should be mentioned that all the measurement reported in the present work is carried out under a low electric field in order to neglect the effect of the injection phenomenon and to be able to write  $i_{\text{p(dipole)}} = i_{\text{d(dipole)}}$ . Hence, from (1) and (2),  $i_{\text{(de-trap)}}$  can be said to be related to  $i_{\text{p(dipole)}}$  and  $i_{\text{d(dipole)}}$  as per the following equation:

$$i_{\text{pol}} - i_{\text{depol}} = i_{\text{(cond.)}} - i_{\text{(de-trap)}} \quad (6)$$

Conduction current  $i_{\text{(cond.)}}$  can be obtained from the final part of the polarisation current

$$i_{\text{(cond.)}} = i_{\text{pol}}(t_{\text{final}}) + i_{\text{depol}}(t_{\text{final}}) \quad (7)$$

where  $i_{\text{pol}}(t_{\text{final}})$  and  $i_{\text{depol}}(t_{\text{final}})$  are the final values of PDC. So from (5) and (6) it is clear that if  $i_{\text{pol}}$ ,  $i_{\text{depol}}$  and  $i_{\text{(cond.)}}$  are known then de-trapping current  $i_{\text{(de-trap)}}$  can be obtained. The discussion presented above coupled with (3) and (4) suggest that the nature of  $i_{\text{(de-trap)}}$  is

exponentially decaying. Hence, in the present work the de-trapping current is approximated by (8) [6]

$$i_{\text{(de-trap)}} = A \exp(-t/\tau) \quad (8)$$

where  $A$  is the amplitude of the de-trapping current,  $t$  is time and  $\tau$  is the time constant of de-trapping current. In the present work, values of  $A$  and  $\tau$  are determined by fitting an exponential decay function with  $i_{\text{(de-trap)}}$  (obtained using (6) and (7)). Once the values of  $A$  and  $\tau$  are determined for a particular transformer, (8) is used to represent its de-trapping current. It is worth mentioning here that  $\tau$  (8) and  $\Gamma$  (4) are not exactly same. The relaxation time  $\Gamma$  mentioned in (4) defines the time taken by a trapped carrier to de-trap, whereas the time constant defined in (8) indicates the time constant of the de-trapping current resulting due to the de-trapping of charge carriers. Both are not numerically same, but they are closely interrelated.

#### 4 Separation of de-trapping current from depolarisation current

The proposed technique of isolating de-trapping current is applied to data collected from several real-life power transformers. The profiles of de-trapping current (isolated from de-polarisation currents of the seven transformers considered in the paper) are presented in Fig. 3a. As explained in the previous section, the dipole current contribution is identified next by subtracting the de-trapping current from measured de-polarisation current. In order to improve readability, the dipole current contribution (obtained from PDCs) is illustrated in Figs. 3b and c, respectively. It can be observed from Figs. 3b and c that dipole current contribution in polarisation and depolarisation are almost same. This reinforces the validity of the de-trapping current profile shown in Fig. 3a.

By using numerical integration, de-trapping charge ( $Q_{\text{detrap}}$ ) can be obtained from de-trapping current as shown by

$$Q_{\text{detrap}} = \int i_{\text{detrap}}(t) dt \quad (9)$$

It is understood that the trapped charge is located at the interface of the oil–paper composite insulation. This implies insulation geometry has a significant effect on the magnitude of de-trapped charge. In order to compare different transformers based on charge content  $Q_{\text{detrap}}$ , the influence of insulation dimensions must be first reduced. The variation of  $R_0$  with  $\tan\delta$  and  $\rho_{\text{pm}}$  is plotted (Figs. 4a and b) for the seven transformers considered in this paper.

$R_0$  or dc resistance is the ratio of charging voltage  $U_0$  and the dc conduction current  $i_{\text{(cond.)}}$  (7). As per (7), the value of  $i_{\text{(cond.)}}$  depends on the final value of PDC at a larger value of time and hence on the physical dimension of the insulation concerned. It is not practically possible to measure  $R_0$  by varying  $\tan\delta$  and  $\rho_{\text{pm}}$  for the real-life transformer. PDC data is a monotonically decreasing dc current that eventually settles down to a constant value. It is a general practice to record polarisation depolarisation current up to the time  $t_f$  when they become asymptote to the time axis. This value of  $t_f$  is insulation dependent influenced by its physical dimension,  $\tan\delta$  and  $\rho_{\text{pm}}$ . For a given unit, the value of  $t_f$  tends to be increase with ageing as  $\tan\delta$  and  $\rho_{\text{pm}}$  increases [4]. As the transformers considered in the present work have different physical dimensions, operational age,  $\tan\delta$ ,  $\rho_{\text{pm}}$ , the value of  $R_0$  for each of these transformers are likely to be different.

It can be observed from Figs. 4a and b that there exist no relationships between  $R_0$  and  $\tan\delta$  (or  $\rho_{\text{pm}}$ ) even though it is reported in [3, 4] that the value of  $R_0$  tends to decrease with increase in  $\tan\delta$  and  $\rho_{\text{pm}}$ . This is primarily due to the fact that the value of dc insulation resistance  $R_0$  is influenced by insulation geometry to a significant extent. It can be understood that the value of  $Q_{\text{detrap}}$  is also most likely to be affected by insulation geometry. Hence, in the present work this is done by dividing  $Q_{\text{detrap}}$  by the value of dc insulation resistance. It is worth mentioning here that

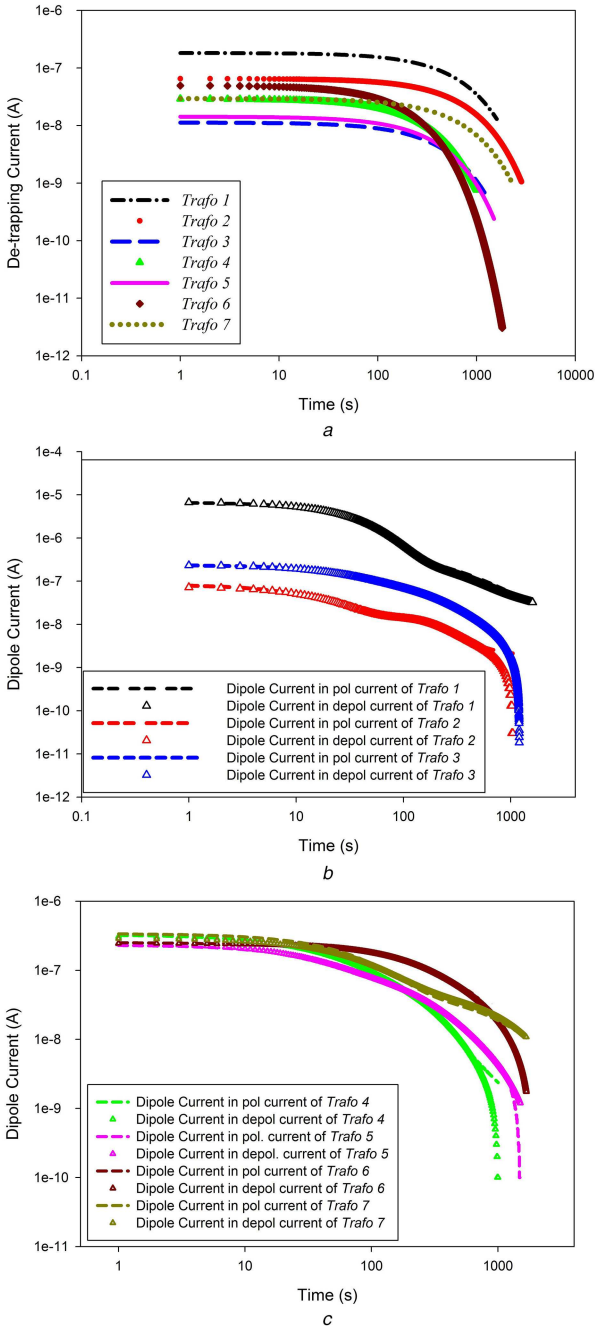

**Fig. 3** De-trapping and dipole currents of different transformers (a) De-trapping current of tested transformers, (b) Dipole current of transformers Trafo1 to Trafo3, (c) Dipole current of transformers Trafo4 to Trafo7

normalisation of  $Q_{\text{detrapp}}$  can be done by any other parameters that are sensitive to insulation geometry. Effect of normalising  $Q_{\text{detrapp}}$  by other factors will be investigated in future communications. Henceforth, in the paper the term ‘normalised de-trapping charge ( $Q_{\text{norm}}$ )’ is used to represent the ratio of  $Q_{\text{detrapp}}$  and  $R_0$  i.e.  $Q_{\text{norm}} = Q_{\text{detrapp}}/R_0$ . Table 2 shows the calculated value of  $Q_{\text{norm}}$ -measured value of  $\% \tan \delta$  and  $\% \text{pm}$  for transformers used in the present work.

In order to investigate the effectiveness of the normalisation procedure, the variation of  $Q_{\text{norm}}$  and  $\% \tan \delta$  (measured) is plotted in Fig. 5.

It is found that the scatter plot shown in Fig. 5 indeed maintains a well-defined relationship that is best represented by

$$\% \tan \delta = -7.139 \times 10^{-16} + 1.824 \times 10^{-16} \times e^{(11.6787 \times Q_{\text{norm}})} \quad (10)$$

In order to improve readability, the fitted curve is also plotted in Fig. 5. The fitted curve shows that  $Q_{\text{norm}}$  maintains a well-defined

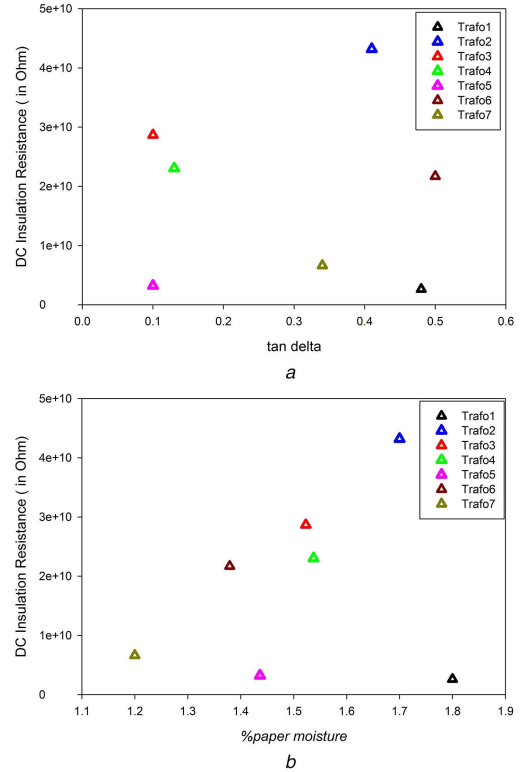

**Fig. 4** Variation of  $R_0$  with performance parameters for different transformers

(a) Variation of  $R_0$  with  $\% \tan \delta$ , (b) Variation of  $R_0$  with  $\% \text{paper moisture}$

relationship with  $\tan \delta$  (a parameter not influenced by geometry [4]). This reinforces the fact that normalised de-trapping charge is less influenced by insulation geometry.

#### 4.1 Effect of de-trapping charge on transfer function zero

The transfer function  $TF_m(s)$  of the structure shown in Fig. 1 is given by

$$TF_m(s) = \frac{N(s)}{D(s)} = \frac{(sR_0C_0 + 1)}{R_0} + \sum_{i=1}^n \frac{sC_i}{(sR_iC_i + 1)} \quad (11)$$

where  $N(s)$  and  $D(s)$  represent the numerator and denominator polynomial of  $TF_m(s)$ , respectively.

According to researchers [27] the root ( $Z_{\text{max}}$ ) of polynomial  $N(s)$  in (11), which has the highest magnitude, is related to the condition of insulation. Research findings reported in [27] suggest that transfer function zero ( $Z_{\text{max}}$ ) that is located furthest away from the origin in the left-hand side of the  $s$ -plane maintains a well-defined relationship with  $\% \tan \delta$  and  $\% \text{pm}$ . Hence, in the present work, efforts are made to investigate the relationship that might exist between  $Q_{\text{norm}}$  and  $Z_{\text{max}}$ . It is worth mentioning here that for the present work, polarisation current is used to find the insulation model and hence its transfer function. Variation of  $Q_{\text{norm}}$  with  $Z_{\text{max}}$  is illustrated in Fig. 6.

Equation (12) is found to best describe the relationship that exists between the data shown in Fig. 6. In order to improve readability, the fitted curve is also included in Fig. 6

$$Z_{\text{max}} = -3.9894 \times 10^{-16} + \frac{5.4536 \times 10^{-14}}{1 + \exp((1.9174 - Q_{\text{norm}})/0.6957)} \quad (12)$$

In an attempt to understand the influence of  $Q_{\text{norm}}$  on the value of  $Z_{\text{max}}$ , the insulation model (from which the transfer function is evaluated) is formulated using both polarisation current and

**Table 2** Normalised charge, %tan $\delta$  and %pm for different transformers

Transformer name	Normalised charge ( $Q_{\text{norm}}$ )	%tan $\delta$ (at 50 Hz)	%pm (IDAX 300)
Trafo1	$4.89 \times 10^{-14}$	0.48	1.80
Trafo2	$2.13 \times 10^{-14}$	0.41	1.70
Trafo3	$1.25 \times 10^{-16}$	0.10	1.40
Trafo4	$3.48 \times 10^{-16}$	0.13	1.50
Trafo5	$1.53 \times 10^{-16}$	0.10	1.40
Trafo6	$4.32 \times 10^{-16}$	0.40	1.30
Trafo7	$1.03 \times 10^{-15}$	0.34	1.20

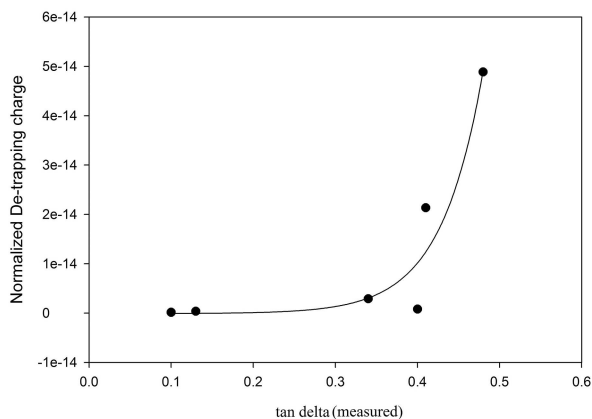
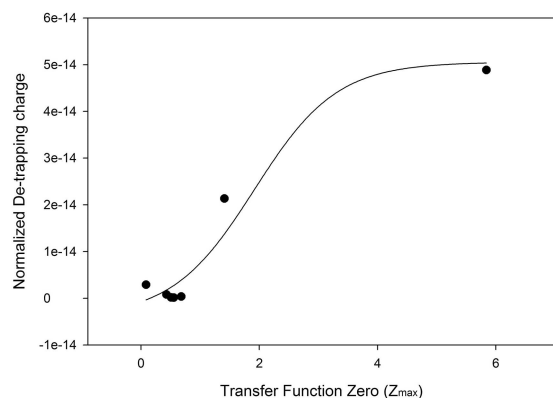
**Fig. 5** Variation of normalised de-trapping charge with tan $\delta$ **Fig. 6** Variation of normalised de-trapping charge and value of  $Z_{\text{max}}$ 

depolarisation current (containing de-trapping current) shown in Table 3.

It can be understood that the data presented in column 2 of Table 3 is obtained using insulation model parameters that are formulated using only dipole contribution. On the other hand, column 3 of Table 3 represents the value of  $Z_{\text{max}}$  that is evaluated using insulation model parameters that are formulated using current that contains contribution of both dipole and de-trapped carriers. It is reported in [27] that  $Z_{\text{max}}$  is not influenced by insulation geometry while remaining sensitive to %tan $\delta$  and %pm. It is also reported in [27] that the value of  $Z_{\text{max}}$  increases as the insulation concerned degrades over time. This implies that  $Z_{\text{max}}$  can be considered as an effective performance parameter. Data presented in Table 3 suggest that de-trapping current can lead to incorrect computation of  $Z_{\text{max}}$  which in turn may lead to inaccurate assessment of insulation health.

#### 4.2 Effect of de-trapping charge on paper moisture

Available literature [10] shows that as the age of transformer increases the insulation degrades. Over time, many bonds are broken in the interfacial region due to different physiochemical reactions. These broken bond sites act as traps where charge

trapping takes place. It is reported [6] that many acidic compounds are formed due to such chemical reactions. Therefore, the quality of insulation reduced and its affinity towards absorption of moistures increased. In addition, Fig. 6 and (12) show that  $Q_{\text{norm}}$  maintains a well-defined relationship with  $Z_{\text{max}}$ , a parameter known to be sensitive to %pm. The above discussion suggests that de-trapping charge is likely to increase with an increase in paper moisture and ageing and hence is worth investigating. Fig. 7 shows the variation of  $Q_{\text{norm}}$  with paper moisture (%pm) content.

It is worth mentioning here that the value of %pm (corresponding to different transformers) used in Fig. 7 are obtained using IDAX 300 equipment.

It is found that (13) best describes the relationship that exists between  $Q_{\text{norm}}$  and %pm

$$\%pm = -4.5564 \times 10^{-16} + 1.5130 \times 10^{-21} \times e^{(9.6177 \times Q_{\text{norm}})} \quad (13)$$

In order to improve clarity the fitted curve is also included in Fig. 7. Fig. 7 depicts that de-trapping charge maintains a good correlation with paper moisture value. This shows that the insulation response of a degraded insulation is likely to be affected by a large de-trapping charge. This is because, as oil-paper insulation degrades over time, bonds in cellulosic material break generating moisture and ionic compounds as by-product. The moisture thus generated further aggravates ageing [4] and also increases the dielectric loss of the insulation as a whole. This degradation of cellulosic material in turn leads to surface imperfections which act as trap sites for charge carriers. This increase in trap sites combined with thermal oscillations in the system leads to increase in overall de-trapping current generation.

## 5 Conclusions

In present work, an approach has been proposed to identify interfacial charge from PDC measurements in transformer oil-paper insulation. For this, the de-trapping current component in depolarisation current, which is solely due to movement of interfacial trapped charge towards electrode and its absorption, is at first separated from the overall depolarisation current. Due to this de-trapping current, non-linearity arises in the system. Therefore, with CDM it is not possible to estimate de-trapping current because it considers the dielectric as linear model. Through integrating it, a charge quantity is obtained, which is further normalised according to transformer geometry. The effect of this normalised de-trapping charge on tan $\delta$ , paper moisture and transfer function zero is analysed in this paper. In fact, results presented in the paper indicate that increase in de-trapping charge  $Q_{\text{norm}}$  suggests increase in %tan $\delta$  and %pm thereby indicating a reduction in desirable properties of insulation. All of these parameters are very sensitive to the insulation health and they depict well-defined correlation with normalised de-trapped charge. For example, it is found that paper moisture value increases with increase in de-trapping charge. The analysis presented here has been performed on several real-life power transformers and the results clearly show the adverse affect of interfacial charge accumulation on transformer insulation. Therefore, it can be said that presented method will be helpful in extracting meaningful information from PDC measurements regarding insulation condition.

**Table 3** Influence of de-trapping current on the value of  $Z_{\max}$ 

Transformer name	Value of $Z_{\max}$ calculated using insulation model formulated from	
	Polarisation current	De-polarisation current
Trafo1	5.041	5.840
Trafo2	1.801	1.308
Trafo3	0.722	0.553
Trafo4	0.841	0.681
Trafo5	0.605	0.508
Trafo6	0.542	0.429
Trafo7	0.118	0.084

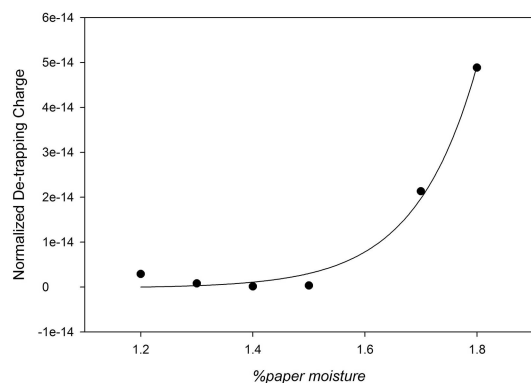
**Fig. 7** Variation of normalised de-trapping charge with %paper moisture

## 6 References

- [1] Saha, T.K., Purkait, P.: 'Investigation of polarization and depolarization current measurements for the assessment of oil–paper insulation of aged transformers', *IEEE Trans. Dielectr. Electr. Insul.*, 2004, **11**, (1), pp. 144–153
- [2] Der, H.V., Zaengl, W.S.: 'Time domain measurements of dielectric response in oil–paper insulation stems'. Int. Symp. Electrical Insulation, Montreal, QC, Canada, 1996, pp. 47–52
- [3] Saha, T.K., Purkait, P., Müller, F.: 'Deriving an equivalent circuit of transformers insulation for understanding the dielectric response measurements', *IEEE Trans. Power Deliv.*, 2005, **20**, (1), pp. 149–157
- [4] Zaengl, W.S.: 'Dielectric spectroscopy in time and frequency domain for HV power equipment, part I: theoretical considerations', *IEEE Electr. Insul. Mag.*, 2003, **19**, (5), pp. 5–19
- [5] Zaengl, W.S.: 'Applications of dielectric spectroscopy in time and frequency domain for HV power equipment', *IEEE Electr. Insul. Mag.*, 2003, **19**, (6), pp. 9–22
- [6] Mishra, D., Haque, N., Baral, A., *et al.*: 'Assessment of interfacial charge accumulation in oil–paper interface in transformer insulation from polarization–depolarization current measurements', *IEEE Trans. Dielectr. Electr. Insul.*, 2017, **24**, (3), pp. 1665–1673
- [7] Zhou, Y., Wang, Y., Li, G., *et al.*: 'Space charge phenomena in oil–paper insulation materials under high voltage direct current', *J. Electrostatics*, 2009, **67**, (2), pp. 417–421
- [8] Wu, K., Zhu, Q., Wang, H., *et al.*: 'Space charge behavior in the sample with two layers of oil-immersed-paper and oil', *IEEE Trans. Dielectr. Electr. Insul.*, 2014, **21**, (4), pp. 1857–1865
- [9] Wang, S., Zhang, G., Mu, H., *et al.*: 'Effects of paper-aged state on space charge characteristics in oil-impregnated paper insulation', *IEEE Trans. Dielectr. Electr. Insul.*, 2012, **19**, (6), pp. 1871–1878
- [10] Fofana, I., Hadjadj, Y.: 'Electrical-based diagnostic techniques for assessing insulation condition in aged transformers', *Energies*, 2016, **9**, (9), p. 679
- [11] Bartnikas, R.: 'Performance characteristics of dielectrics in the presence of space charge', *IEEE Trans. Dielectr. Electr. Insul.*, 1997, **4**, (5), pp. 544–557
- [12] Bartnikas, R.: 'Dielectric losses in solid-liquid insulating systems – part I', *IEEE Trans. Electr. Insul.*, 1971, **5**, pp. 113–121, 1970; also Part II, 6, pp. 1421
- [13] Watson, P.K.: 'The transport and trapping of electrons in polymers', *IEEE Trans. Dielectr. Electr. Insul.*, 1995, **2**, (5), pp. 915–924
- [14] Mazzanti, G., Montanari, G.C., Palmieri, F., *et al.*: 'Apparent trap-controlled mobility evaluation in insulating polymers through depolarization characteristics derived by space charge measurements', *J. Appl. Phys.*, 2005, **94**, (9), pp. 5997–6004
- [15] Tang, C., Chen, G., Fu, M., *et al.*: 'Space charge behavior in multilayer oil–paper insulation under different DC voltages and temperatures', *IEEE Trans. Dielectr. Electr. Insul.*, 2010, **17**, (3), pp. 775–784
- [16] Meunier, M., Quirke, N., Aslanides, A.: 'Molecular modeling of electron traps in polymer insulators: chemical defects and impurities', *J. Chem. Phys.*, 2001, **115**, (6), pp. 2876–2881

- [17] Meunie, M., Quirke, N.: 'Molecular modeling of electron trapping in polymer insulators', *J. Chem. Phys.*, 2000, **113**, (1), pp. 369–376
- [18] Chen, G., Xu, Z.: 'Charge trapping and detrapping in polymeric materials', *J. Appl. Phys.*, 2009, **106**, (12), p. 123707
- [19] Zhou, T., Chen, G., Liao, R., *et al.*: 'Charge trapping and detrapping in polymeric materials: trapping parameters', *J. Appl. Phys.*, 2011, **110**, (4), p. 043724
- [20] Fabiani, D., Montanari, G.C., Cavallini, A., *et al.*: 'Relation between space charge accumulation and partial discharge activity in enameled wires under PWM-like voltage waveforms', *IEEE Trans. Dielectr. Electr. Insul.*, 2004, **11**, (3), pp. 393–405
- [21] Haque, N., Dalai, S., Chatterjee, B., *et al.*: 'Investigations on charge trapping and de-trapping properties of polymeric insulators through discharge current measurements', *IEEE Trans. Dielectr. Electr. Insul.*, 2017, **24**, (1), pp. 583–591
- [22] Haque, N., Chatterjee, B., Dalai, S., *et al.*: 'Studies on the effect of temperature on the charge trapping and de-trapping processes of polymeric insulators through depolarization current measurements', *IEEE Trans. Dielectr. Electr. Insul.*, 2017, **24**, (3), pp. 1896–1904
- [23] Zhou, Y., Huang, M., Chen, W., *et al.*: 'Space charge behavior evolution with thermal aging of oil–paper insulation', *IEEE Trans. Dielectr. Electr. Insul.*, 2015, **22**, (3), pp. 1381–1388
- [24] Wei, Y.H., Mu, H.B., Deng, J.B., *et al.*: 'Effect of space charge on breakdown characteristics of aged oil–paper insulation under DC voltage', *IEEE Trans. Dielectr. Electr. Insul.*, 2016, **23**, (5), pp. 3143–3150
- [25] Lakshminarayana, K., Dasararhuhu, Y., Narasimha Rao, V.V.R.: 'Charging and discharging currents in poly (vinyl pyrrolidone) polymer thin films', *Mater. Chem. Phys.*, 1995, **42**, pp. 206–209
- [26] Neagu, E.R., Neagu, R.M.: 'On the nature of the origin of the isothermal and non-isothermal current released from dielectric materials', *Thin Solid Films*, 2001, **384**, pp. 15–22
- [27] Baral, A., Chakravorti, S.: 'Condition assessment of cellulosic part in power transformer insulation using transfer function zero of modified debye model', *IEEE Trans. Dielectr. Electr. Insul.*, 2014, **21**, (5), pp. 2028–2036

## 7 Appendix

PDC measurement is an offline technique that comes under time-domain spectroscopy. PDC data of a transformer unit is recorded for several thousand seconds under steady voltage. Prior to the measurement of PDC data of a transformer unit, low- and high-voltage windings are short-circuited and kept for sufficient time to remove any residual charge within it. Thereafter, the terminals of both the high- and low-voltage windings are made short-circuited. These shorted terminals make the two electrodes through which the dc excitation voltage is applied during polarisation current measurement. Typical value of charging voltage is considered as 1000 V during polarisation current measurement [4]. Due to very low magnitude of relaxation current, generally electrometer is used for recording purpose. In the present work, PDC data of different power transformers (details given in Fig. 8a) are recorded using KEITHLEY 6517B Electrometer based instrument that has been developed at High Tension Laboratory of Jadavpur University. Figs. 8a and b show the schematic diagram of equipment used for PDC measurement. Using the developed setup (as shown in Fig. 8b), the PDC current of transformers (as given in Fig. 2) has been measured.

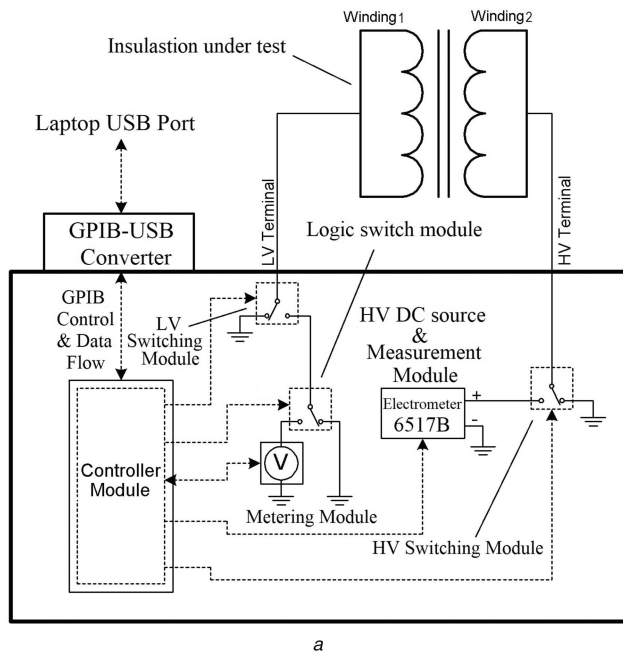

**Fig. 8** Developed instrument for measuring PDC data  
 (a) Schematic diagram of developed instrument, (b) Final form