

Reliable Assessment of Oil-Paper Insulation Used in Power Transformer Using Concise Dielectric Response Measurement

Deepak Mishra, *Member, IEEE*, Arijit Baral, *Senior Member, IEEE*, and Sivaji Chakravorti, *Senior Member, IEEE*

Abstract—Oil-impregnated paper is usually the preferred choice of insulation in power transformers. The working life of any transformer depends on its insulation condition. The paper conductivity, moisture content and dissipation factor of solid insulation are a few crucial parameters used to determine the insulation condition. The reliable estimation of such parameters for diagnosis of solid insulation requires a complete profile of polarization current which is time-consuming. Hence, utilities always prefer non-invasive and rapid techniques to predict insulation conditions and minimize shutdown time. The proposed technique is based on a short-duration polarization current data. The present manuscript suggested a method that uses the initial decay rate of recorded polarization current data to predict various performance parameters related to paper insulation. In order to show the effectiveness of the proposed method, the analysis is performed on the data measured from various in-situ transformers.

Index Terms— Dielectrics, Power Transformers, Insulation, Dielectric Measurement, Conductivity measurement, Moisture Content, Time-Domain analysis.

I. INTRODUCTION

Oil-paper Insulation (OPI) is a popular choice for insulation in power transformers due to its high dielectric strength and heat dissipation capability [1]-[4]. During operating conditions, transformer insulation faces various electrical, mechanical and thermal stresses simultaneously. If unchecked, this aging may lead to unit failure. Hence, insulation condition monitoring is needed to avoid the failure of power transformers. In recent times, both Time Domain Spectroscopy (TDS) and Frequency Domain Spectroscopy (FDS) based methods have been used for assessing the insulation condition due to their non-invasive behavior [4]-[9]. The traditional frequency-domain spectroscopy-based measurement is time-consuming (especially in low-frequency regions) which is not advantageous for utilities. On the other hand, the typical measurement time of Polarization-Depolarization Current (PDC) data (a time domain-based method) is about 20000s

[9]. Being a time-series data, the time-domain dielectric response testing time can be reduced to a certain extent [10]. Hence, the present work is oriented towards analyzing polarization current data.

Paper conductivity (σ_{paper}), moisture content (%*pm*) and dissipation factor (%*tand*) are crucial aging-sensitive parameters that provide the quantitative evaluation of overall condition of the insulation. The major advantage of PDC based method is that it provides a straightforward approach to predicting such parameters of the cellulosic part of oil-paper composite insulation. Available literature shows that prediction of insulation-sensitive parameters (related to paper insulation) requires a complete profile of polarization current data [10]-[12] which typically requires 10000s to complete. Before conducting the polarization current measurement test, the concerned transformer is disconnected from the grid and allowed 'cooling time,' to achieve thermal equilibrium. The concerned utility generally decides this cooling time. The typical testing time varies from several minutes to a few hours, depending on the response time of the dipole present in the dielectric material. Such a long data measurement time for which the transformer unit remains dissociated from the grid is not advantageous for utilities from an economic point of view.

During field measurement, external factors like low-frequency noise [13] and variation in ambient temperature [12] may also influence the measured data (especially at a larger value of time). Analysis of such incorrect data may provide misleading information regarding the insulation state. Consequently, multiple data recordings need to be carried out to ensure reliable data measurement. Previous literatures have reported many techniques to predict aging-sensitive parameters related to paper insulation based on dielectric response analysis [11], [14]. However, all such reported methods require complete recorded data [11], [14]. Few other methods that take less time to predict such parameters are also reported, but such techniques need intensive signal processing [14]-[15].

Considering the problems associated with long testing time, a novel and time-effective approach is proposed in the present paper. The proposed technique makes prediction of aging sensitive parameters related to paper insulation possible using data measured for only 15 to 20 s. At the initial stages of development, complete profiles of polarization current are measured from a few real-life transformers (whose details are mentioned in Table I). Thereafter, the insulation model (also

Deepak Mishra is with the Electrical Engineering Department, Indian Maritime University Kolkata, India (e-mail: deepak2010urs@gmail.com).

Arijit Baral is with the Electrical Engineering Department, Indian Institute of Technology (Indian School of Mines), Dhanbad, India (e-mail: arijit@iitism.ac.in).

Sivaji Chakravorti is with the Electrical Engineering Department, Jadavpur University, Kolkata, India (e-mail: s_chakrav@yahoo.com).

called the ‘Debye Model’) is formulated using the recorded data as reported in [9], [17]-[18]. After this, the system's Transfer Function is evaluated using branch parameters of the constructed Debye model. Next, the *Rise Time* of the system is evaluated using the Transfer Function. Thereafter, the variation between various performance parameters and *Rise Time* is investigated. After analyzing the results, it is found that insulation-sensitive parameters (obtained from different transformers) maintain a well-defined relationship with *Rise Time*. In the next stage, a variation between the initial decay rate (obtained using the initial 15-20s of recorded data) of polarization current and *Rise Time* is investigated. It is found that *Rise Time* also maintains a specific relation with decay rate.

After combining all the information related to performance parameters, *Rise Time*, initial decay rate, a technique is proposed which is capable of estimating different parameters using the initial slope of the measured dielectric current. Results reported in the paper show that only a few seconds of recorded data (about 20s) is sufficient to predict the initial decay rate value and various performance parameters. It should be mentioned here that initially complete profile of polarization current is used to develop the relationship. Once the relationships are developed, only a few seconds of tested data (about 20s) is needed to estimate different parameters like σ_{papers} , $\%pm$ and $\%tan\delta$. The proposed method is validated by comparing the estimated value of different performance parameters (using the proposed method) with their measured value.

is referred to as the measured value. Other performance parameters used in the present work are measured using commercial equipment. In the present work, the polarization current used for analysis is recorded from a 6517B Electrometer at Jadavpur University Kolkata. The setup and polarization current profiles recorded from a few in-service transformers are shown in Figure 1 and 2, respectively.

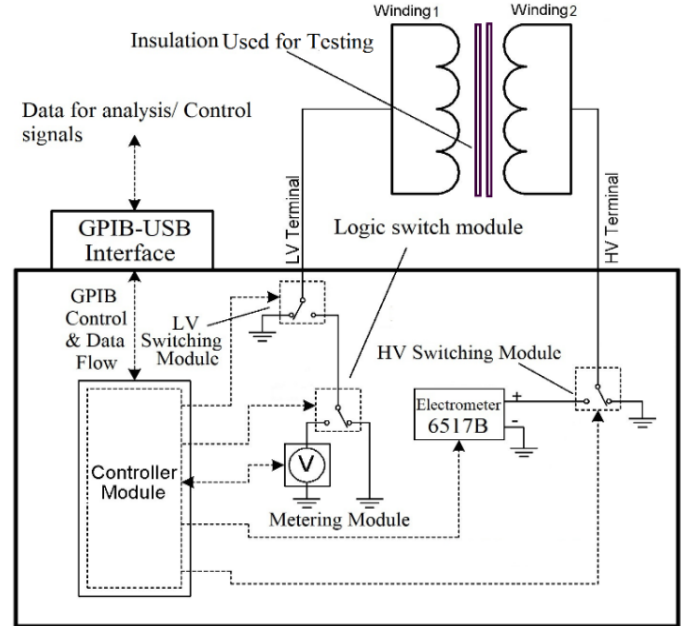

Fig. 1. Schematic of equipment used to record polarization current profile [19]

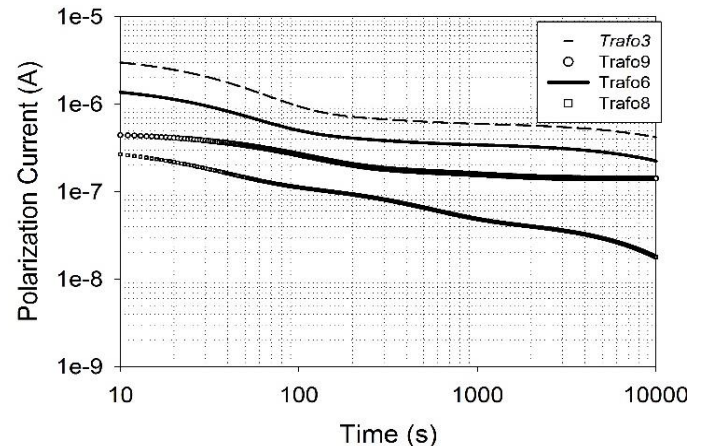

Fig. 2. Profile of polarization current measured from a few in-service transformers

Measurement of conventional PDC data itself takes a few hours to complete [9]. The paper's main aim is to reduce the measurement time of polarization current, which starts after the equipment reaches thermal equilibrium. In fact, all Dielectric Response based measurements are expected to be measured at thermal equilibrium. Otherwise, analysis using such data will lead to inaccurate diagnosis [12]. The proposed methodology is applicable to data recorded from an offline transformer after it has cooled down and reached thermal equilibrium.

TABLE I

POWER RATING AND APPROXIMATE AGE OF TRANSFORMERS USED IN THE PRESENT WORK

SI. No.	Transformer Name	Power Rating	Approx. operating Age (in Years)
1	TRFO1	240MVA, 400kV	08 – 11
2	TRFO2	270MVA, 220kV	06 – 08
3	TRFO3	240MVA, 420kV	30 – 33
4	TRFO4	240MVA, 400kV	21 – 23
5	TRFO5	200MVA, 420kV	31 – 34
6	TRFO6	125MVA, 220kV	20 – 22
7	TRFO7	240MVA, 400kV	23 – 26
8	TRFO8	250MVA, 242kV	07 – 09
9	TRFO9	240MVA, 400kV	12 – 14
10	TRFO10	200MVA, 420kV	24 – 27
11	TRFO11	270MVA, 220kV	04 – 06
12	TRFO12	290MVA, 230kV	18 – 21
13	TRFO13	200MVA, 420kV	14 – 17
14	TRFO14	220MVA, 400kV	22 – 25
15	TRFO15	200MVA, 420kV	15 – 17

It is worth mentioning here that the conductivity value obtained using a complete profile of polarization current data

II. BRIEF THEORY ABOUT POLARIZATION CURRENT

In the presence of a dc electric field, polarization current is generated due to the alignment of dipole groups present in dielectric material in the direction of the applied field. Typically a dc voltage of 1000V is used in the case of an in-service transformer [1]. It is worth mentioning here that "cooling time" allowed to an equipment, prior testing, helps the transformer attain thermal equilibrium and reduces the residual charge's effect [19]-[20].

As per the linear dielectric theory, the dielectric current has two components; one is due to the polarization property of dipoles ($i_{polarization}$), while the other is conduction current (i_{cond}). Conduction current in recorded polarization current is mainly observed due to ionic movement. Equation (1a) represents the dielectric current [20]

$$i_{dielectric} = i_{polarization} + i_{cond} \quad (1a)$$

$$i_{polarization} = i_{absorption} + i_{displacement} \quad (1b)$$

In equation (1b), $i_{polarization}$ represents the current generated due to different polarization processes. On the other hand, $i_{displacement}$ in equation (1b) denotes the contribution of electronic and ionic polarization processes, while $i_{displacement}$ represents the contribution due to dipole polarization [21]-[22]. It is well known that ionic and electronic polarization processes are very fast. Hence, their effect usually does not significantly affect the profile of polarization current.

In practice, utility measure the slow dipolar polarization-related data. Insulation models are generally used to analyze the recorded polarization current data [9], [15]-[17], [22]. The Classical Debye Model (CDM) is one such popular model used for analyzing the measured polarization current data. Different dipole groups present in dielectric material have different relaxation times. Hence, CDM is represented by the parallel combination of series resistive-capacitive branches. Figure 3 shows the structure of a CDM.

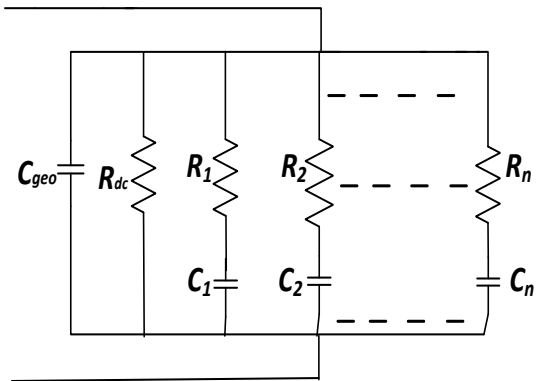

Fig. 3. Conventional Debye Model structure used for analyzing the dielectric response

In Figure 3, each branch of CDM, represents characteristics of different dipole groups present in insulation. R_{dc} and C_{geo} in Figure 3 show the dc insulation resistance and geometrical capacitance, respectively. Available literature suggests that branches of insulation model having a time constant less than

100s represent the oil properties, while the branches having a time constant greater than 1000s signify the attributes of paper insulation [9]. On the other hand, branches whose time constant lies between 100s and 1000s represent the features of interfacial region [9].

III. RISE TIME PREDICTION USING TRANSFER FUNCTION OF INSULATION MODEL

Reliable branch parameter identification of CDM is crucial for adequately modelling polarization current. Polarization current can be considered as the response of CDM excited by step voltage $U(t)$, which is given by equation (2)

$$U(t) = V_{dc}; t > 0^+ \\ = 0; t < 0^- \quad (2)$$

In equation (2), V_{dc} denotes the applied voltage to record polarization current. The Transfer Function of the insulation model is usually represented by equation (3) [15]

$$TF_{CDM}(s) = \frac{sR_{dc}C_{geo}}{R_{dc}} + \sum_{n=1}^N \frac{s \times 1/R_n}{s + 1/(R_n C_n)} \quad (3)$$

The Transfer Function given in equation (3) can be represented by the standard form of a Transfer Function, which is shown by equation (4)

$$TF_{CDM}(s) = \frac{Num(s)}{Den(s)} \quad (4)$$

Here, in equation (4), $Num(s)$ and $Den(s)$ are represented as given below

$$Num(s) = p_{N+1}s^{N+1} + p_N s^N + \dots + p_1 s^1 + p_0$$

$$Den(s) = q_N s^N + q_{N-1} s^{N-1} + \dots + q_1 s^1 + q_0$$

It can be understood from equation (3) that each branch of the Debye Model contributes to a negative real pole except branches representing R_{dc} and C_{geo} . The steady-state value of monotonically decreasing step response of $TF_{CDM}(s)$ is given by (5) [17]-[18]

$$\lim_{s \rightarrow 0} s \times \left(TF_{CDM} \times \frac{V_{dc}}{s} \right) = \frac{p_0}{q_0} \times V_{dc} = \frac{V_{dc}}{R_{dc}} \quad (5)$$

It can be further observed from equation (3) that the order of the numerator is more than the denominator. Thus, $TF_{CDM}(s)$ can be represented by the series combination of two distinct Transfer Functions $(s+Z_1)$ and $(TF'' = Num''(s)/Den(s))$ shown in Figure 4.

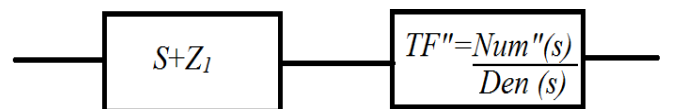

Fig.4. Prediction of TF_{CDM} using the series combination of two Transfer Function

Now, $TF_{CDM}(s)$ can be represented by equation (6)

$$TF_{CDM}(s) = (S + Z_1) \times \frac{Num''(s)}{Den(s)} \quad (6)$$

For a given step voltage V_{dc} , the response of the system is given by equation (7) [15]

$$I_{polarization}(s) = \left(\frac{(s + Z_1) \times N''(s)}{D(s)} \right) \times \frac{V_{dc}}{s} \quad (7)$$

After reliable prediction of step response, it is possible to estimate the decay rate (initial) and *Rise Time*.

IV. ESTIMATION OF PAPER CONDUCTIVITY USING THE X-Y MODEL

X-Y model was developed to model the relaxation characteristics of insulation while keeping in mind the geometrical arrangement of spacers, barriers and oil ducts [11]. The time-domain relaxation current measurement is generally performed by applying a step voltage to one winding with the current sensing module placed between the other winding and the earth. It is a known fact that the axial length of each winding is greater than the radial distance between the windings. Therefore, the insulation between the yoke and winding has less influence on measured PDC than in the radial direction [11]. Hence, the insulation structure can be represented by the series connection of pressboard barriers with oil ducts and spacers [11]. In order to have further simplification of this complex arrangement, the oil ducts, spacers and barriers are sometimes combined, resulting in a simplified structure shown in Figure 5. In this X-Y model, X represents the ratio of the aggregate thickness of all barriers present in the duct to the duct width. At the same time, spacer coverage Y is the ratio of the total width of spacers to the periphery of the ducts. The ranges of Y and X that are generally considered for analysis lie between %10-30% and 20%-50%, respectively [11]. In the present work, the X is considered as 30%.

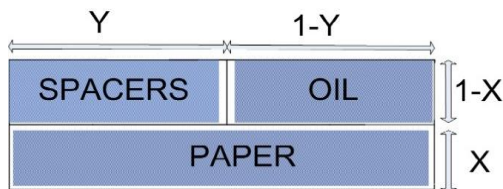

Fig.5. Simplified X-Y model of Transformer insulation

Existing literature reported that the steady state part of polarization current (also called conduction current) is related to dc conductivity [11] given by equation (8)

$$\sigma_{dc_c} \approx \frac{\epsilon_0 \times i_{cond}}{C_{geo} V} \quad (8)$$

In equation (8), σ_{dc} represents paper conductivity while ϵ_0 signifies the permittivity of free space. σ_{dc_c} is also related with paper conductivity (σ_{paper_c}) which is represented by equation (9)

$$\sigma_{dc_c} = \frac{\sigma_{oil_c} \times \sigma_{paper_c}}{\sigma_{paper_c} \times (1 - X) + \sigma_{oil_c} \times X} \quad (9)$$

σ_{oil_c} in equation (9) represents the oil conductivity which can be easily predicted using the initial value of recorded dielectric response data [11]. Once the value of σ_{dc_c} and

σ_{oil_c} is known, σ_{paper_c} can be predicted using equation (9).

The estimated value of paper conductivity for different transformers (details given in Table I) is given in Table II. It is worth mentioning here that the values of paper conductivity mentioned in Table II are considered as measured values for this work.

TABLE II
PAPER CONDUCTIVITY OF VARIOUS TRANSFORMERS UNDER STUDY

SI. No.	Transformer Name	Paper Conductivity(S/m) (Scaled by 10^{13})
1	TRFO1	1.240
2	TRFO2	3.580
3	TRFO3	0.25
4	TRFO4	0.16
5	TRFO5	0.054
6	TRFO6	4.599
7	TRFO7	1.64
8	TRFO8	0.24
9	TRFO9	0.323
10	TRFO10	0.09
11	TRFO11	3.08
12	TRFO12	0.701
13	TRFO13	5.10
14	TRFO14	2.80
15	TRFO15	6.324

V. VARIATION OF VARIOUS INSULATION SENSITIVE PARAMETERS WITH RISE TIME

A. Paper Conductivity

Throughout its operational life, paper insulation experiences various stresses which degrade the paper quality, causing an increment in paper conductivity [9], [23]. The values of *Rise Time* calculated for various transformers are given in Table III. In order to develop the proposed method, the *Rise Time* is initially calculated from $TF_{CDM}(s)$ (formulated using the complete profile of polarization current recorded for 10,000s). Later in the paper, it is shown that the value of *Rise Time* and hence, paper conductivity can be obtained using short-duration polarization current data. Table III shows the value of *Rise Time* obtained for the different transformers. Figure 6 shows the scatter plot (using data given in Tables II and III) between paper conductivity and *Rise Time* (R_T).

TABLE III
CALCULATED VALUES OF RISE TIME FOR VARIOUS TRANSFORMERS UNDER STUDY

SI. No.	Transformer Name	Rise Time
1	TRFO1	181.8
2	TRFO2	132.098
3	TRFO3	244.47
4	TRFO4	249.15
5	TRFO5	340.99
6	TRFO6	121.5
7	TRFO7	157.8
8	TRFO8	274.8
9	TRFO9	232.2
10	TRFO10	310.4
11	TRFO11	138.2
12	TRFO12	198.4
13	TRFO13	114.2
14	TRFO14	128.2
15	TRFO15	106.6

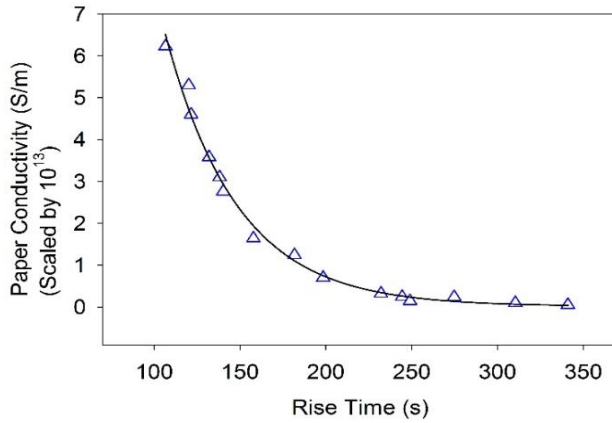

Fig. 6. Variation of Paper conductivity with Rise Time

It is clear from Figure 6 that Paper conductivity maintains a well-defined relationship with Rise Time (R_T). It is observed that the relationship between the data shown in Figure 6 can be approximated by equation (10). The relationship approximated by equation (10) is also shown in Figure 6.

$$\sigma_{paper_c} = 0.182 + 81.7661 \times \exp(-0.0238 \times R_T) \quad (10)$$

The degree of correlation (R^2) for the fitted curve shown in Figure 6 is found to be 0.99, which is significantly high and represents a good correlation. It can be opined from Figure 6 that as the value of R_T increases, the value of paper conductivity decreases.

B. Moisture Content

Moisture content in paper insulation is another crucial performance parameter that utilities observe. An increment in the moisture content leads to the deterioration of desirable properties of insulation [1][2][15]. It is worth mentioning here that the value of moisture content (% pm) used here is obtained using either *IDAX 300* or *DIRANA* equipment. As per the information provided by the utility, a given piece of equipment is generally used for data measurement at different installation sites. Hence, the choice of equipment used for

measurement purposes was decided based on the availability of the said equipment. The values of % pm and estimated R_T for different tested transformers are given in Table IV. Figure 7 shows the scatter plot of data given in Table IV. It can be observed from Figure 7 that R_T follows a well-known standard relationship with % pm .

TABLE IV
VALUES OF %PM AND RISE TIME OBTAINED FROM DIFFERENT TRANSFORMERS

Transformer Name	%pm (using IDAX 300 /DIRANA)	Rise time (s)
TRFO1	1.1	181.8
TRFO2	1.6	132.098
TRFO3	0.8	244.47
TRFO4	NA*	249.15
TRFO5	0.6	340.99
TRFO6	1.8	121.5
TRFO7	1.4	157.8
TRFO8	NA*	274.8
TRFO9	0.8	232.2
TRFO10	0.6	310.4
TRFO11	NA*	138.2
TRFO12	1.0	198.4
TRFO13	2.0	114.2
TRFO14	1.9	128.2
TRFO15	2.4	106.6

*NA: Data Not Available

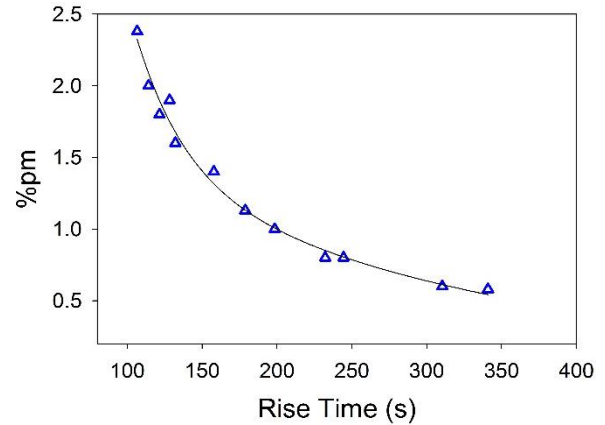

Fig. 7. Variation of % pm with Rise Time of system

It is observed that the relationship between the data shown in Figure 7 can be approximated by equation (11). The relationship approximated by equation (11) is also shown in Figure 7.

$$\%pm = 2.06 \times \exp(-3.9 \times 10^{-3} R_T) + 24.21 \times \exp(-3.02 \times 10^{-2} R_T) \quad (11)$$

It should be mentioned here that the degree of correlation (R^2) for the fitted curve is 0.996. Hence, it can be opined from Figure 7 that an increment in the value of R_T leads to the reduction of % pm .

C. Dissipation Factor ($\%tan\delta$)

In addition to paper conductivity and $\%pm$, the dissipation factor ($\%tan\delta$) is also considered an important parameter commonly used by utilities to assess the insulation condition [18]. It is the measure of dielectric losses in the dielectric material. The dissipation factor is significantly influenced by aging and hence conductive-by-product [18]. As per existing literature, the value of $\%tan\delta$ shows increasing nature with the aging of insulating material [18]. The present work focuses on developing relationships between the Rise time and $\%tan\delta$ (measured at power frequency). In the current work, the value of $\%tan\delta$ was measured using either TETTEX MIDAS or IDAX 300 or DIARANA. Table III shows the values of $\%tan\delta$ measured for different transformers used in the present work.

TABLE V

VALUE OF DISSIPATION FACTOR OBTAINED FROM DIFFERENT TRANSFORMERS

Transformer Name	$\%tan\delta$ (IDAX / DIRANA / TETTEX MIDAS)
TRFO1	0.17
TRFO2	0.30
TRFO3	0.08
TRFO4	0.09
TRFO5	0.07
TRFO6	0.34
TRFO7	0.23
TRFO8	0.09
TRFO9	0.10
TRFO10	0.08
TRFO11	0.24
TRFO12	0.13
TRFO13	0.39
TRFO14	0.28
TRFO15	0.41

Figure 8 shows the scatter plot between R_T and $\%tan\delta$. It can be observed from Figure 8 that $\%tan\delta$ indeed maintains a well-defined relationship with R_T . This relationship can be approximated by equation (12). In order to have a clear understanding of the graph, the curve represented by equation (12) is also included in Figure 8. The degree of correlation (R^2) between the fitted curve and plotted data is found to be 0.97.

$$\%tan\delta = 2.343 \times \exp(-0.0178 \times R_T) + 0.065 \times \exp(-3.38 \times 10^{-12} \times R_T) \quad (12)$$

It can be observed from Figure 8 that as the value of R_T increases, the value of $\%tan\delta$ tends to decrease. Furthermore, equation (12) can be used to estimate $\%tan\delta$ once the value of R_T is known.

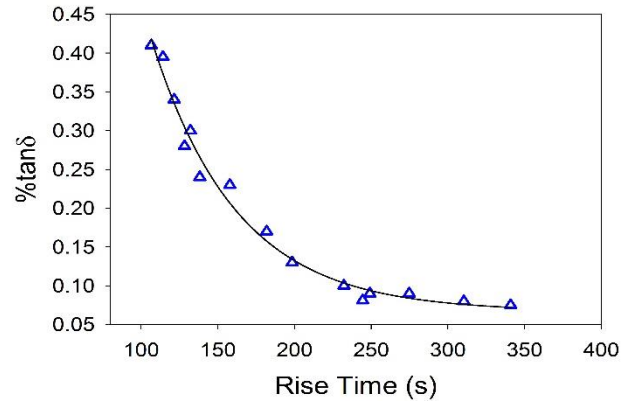

Fig. 8. Variation of $\%tan\delta$ with Rise Time of system

VI. VARIATION OF RISE TIME WITH INITIAL DECAY RATE

Once the reliable value of R_T is predicted, estimation of paper conductivity, $\%pm$ and $\%tan\delta$ is easily possible using equations (10) through (12). After investigation, it is found that the initial decay rate (IDR) of recorded dielectric current maintains a specific relationship with R_T . The migration or movement of interfacial charge becomes slow through oil due to the aging process, which ultimately causes the lower overall decay rate of recorded polarization current data [22]. In order to predict the decay rate, initially measured data for a few seconds (only up to 15-20s) are fitted with a single exponent. Figure 9 shows the relationship between Rise Time and IDR of recorded data.

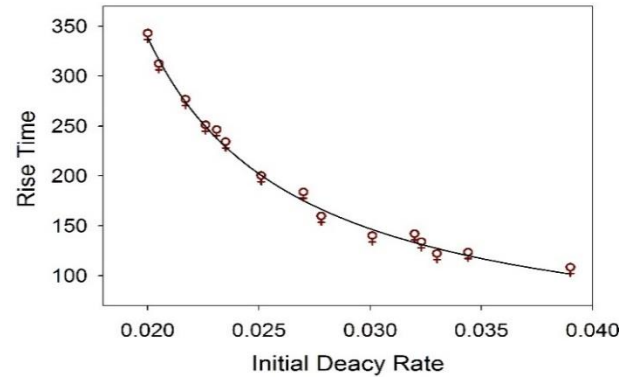

Fig. 9. Variation of Rise Time with the Initial Decay Rate

It is found that the relationship between the data shown in Figure 9 can be approximated by equation (13). In order to improve readability, the curve represented by equation (13) is also included in Figure 9.

$$R_T = \frac{(1.9507 + 17.2634 \times IDR)}{-0.0132 + IDR} \quad (13)$$

The degree of correlation (R^2) for the plot shown in Figure 9 is observed to be 0.99. From the above discussion, it can be opined that using IDR (obtained from short-duration polarization current), it is possible to predict R_T from equation (11). Once the value of R_T is known, performance parameters can be estimated easily using equations reported earlier in the paper.

VII. VALIDATION OF PROPOSED TECHNIQUE

In order to test the effectiveness of the suggested technique, the polarization current is initially recorded from each transformer (details reported in Table I) for about 20 s. Thereafter, this data is used to find IDR. Once the value of IDR is obtained, R_T and other performance parameters are calculated. A comparison between the measured and calculated value of the performance parameters for different transformers is provided in Table VI through VIII. It is clear from the data given in these Tables that there is almost no significant deviation between the measured and predicted values. To illustrate the effectiveness of the proposed method, the percentage deviation ($\%error$) is calculated between measured and predicted values for each performance parameter. The $\%error$ is given in the last column of Table VI through VIII.

TABLE VI
MEASURED AND CALCULATED VALUES OF PAPER CONDUCTIVITY FOR VARIOUS TRANSFORMERS UNDER STUDY

Transformer Name	σ_{paper_c} (Measured (Scaled by 10^{13}))	σ_{paper_c} (Predicted Using (10)) Scaled by 10^{13})	$ \%error $
TRFO1	1.24	1.28	3.22
TRFO2	3.58	3.77	5.30
TRFO3	0.25	0.274	9.60
TRFO4	0.16	0.176	10.0
TRFO5	0.054	0.049	9.25
TRFO6	4.599	4.712	2.45
TRFO7	1.64	1.577	3.81
TRFO8	0.24	0.214	10.83
TRFO9	0.323	0.351	8.66
TRFO10	0.090	0.082	8.88
TRFO11	3.08	2.79	9.41
TRFO12	0.701	0.71	1.28
TRFO13	5.10	4.61	9.60
TRFO14	2.80	3.08	10.0
TRFO15	6.324	6.946	9.83

TABLE VII
MEASURED AND CALCULATED VALUES OF $\%pm$ FOR VARIOUS TRANSFORMERS

Transformer Name	$\%pm$ (Measured (using IDAX / DIRANA))	$\%pm$ (predicted Using (11))	$ \%error $
TRFO1	1.1	1.12	2.00
TRFO2	1.6	1.64	2.50
TRFO3	0.8	0.812	1.50
TRFO4	NA*	0.769	–
TRFO5	0.6	0.54	10.0
TRFO6	1.8	1.86	3.33
TRFO7	1.4	1.28	8.57
TRFO8	NA*	0.72	–

TRFO9	0.8	0.86	7.50
TRFO10	0.6	0.62	3.33
TRFO11	NA*	1.51	–
TRFO12	1.0	1.02	2.0
TRFO13	2.0	2.06	3.0
TRFO14	1.9	1.72	9.47
TRFO15	2.4	2.34	2.5

NA*: Data Not Available

It is clear from the data given in Table VI through VIII that the deviation between the measured and predicted value of different performance parameters is relatively low and under 10%. Thus, it can be opined that the suggested method can identify critical performance parameters like $\%pm$ with satisfactory accuracy using polarization current (measured for only for 20s). Furthermore, the value of the performance parameters predicted by the proposed method is close to that obtained using costly commercial equipment, which requires a significantly larger time to operate [24]- [25].

TABLE VIII
MEASURED AND CALCULATED VALUES OF $\%tan\delta$ FOR VARIOUS TRANSFORMERS

Transformer Name	$\%tan\delta$ (using IDAX / DIRANA/ TETTEX MIDAS)	$\%tan\delta$ (predicted Using (12) & 11))	$ \%error $
TRFO1	0.17	0.158	7.05
TRFO2	0.30	0.28	6.66
TRFO3	0.08	0.87	8.75
TRFO4	0.09	0.092	2.22
TRFO5	0.07	0.071	1.42
TRFO6	0.34	0.33	2.94
TRFO7	0.23	0.21	3.81
TRFO8	0.09	0.083	7.07
TRFO9	0.10	0.106	6.0
TRFO10	0.08	0.074	7.50
TRFO11	0.24	0.26	8.33
TRFO12	0.13	0.133	2.30
TRFO13	0.39	0.372	4.61
TRFO14	0.28	0.304	8.57
TRFO15	0.41	0.416	1.46

VIII. OTHER APPLICATIONS OF THE PROPOSED METHODOLOGY

In order to further show the capability of the proposed technique, two practical issues are considered that are commonly encountered during field measurement. These problems make the recorded data profile non-monotonic and thus very difficult to analyze using the available technique. These problems are:

- Effect of low-frequency non-stationary noise.
- Effect of ambient temperature variation

Applying the proposed methodology can be helpful in such cases, as described in the following two cases.

Case A. Application of Proposed methodology on 270 MVA 220 kV Transformer (TRFO16)

During field measurement, the effect of low-frequency noise is quite common due to low magnitude of polarization current (range from nA to μA) [13]. Figure 10 shows the effect of low-frequency noise on polarization recorded from power transformer insulation. The primary reason behind this low-frequency noise may be other energized equipment near the transformers' vicinity and atmospheric conditions [13]. With such noisy data, constructing an insulation model and hence, estimation of performance parameter is not possible [13]. The data shown in Figure 10 must be pre-processed (like some denoising technique) before being used for analysis. On the other hand, using the proposed methodology, only 15-20s recorded data is sufficient to predict a host of performance parameters without going through any complex mathematical procedure or model. It is clear from Table IX that the values of paper conductivity and $\%tan\delta$ estimated using the suggested technique are very close to that of their measured value.

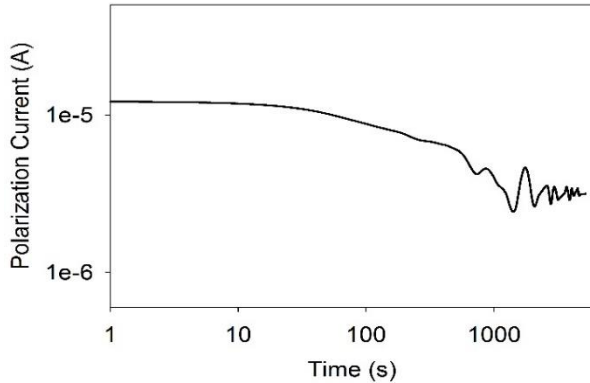

Fig. 10. Influence of low-frequency noise on recorded dielectric response

Case B. Application of Proposed methodology on 200 MVA 765 kV Transformer (TRFO17)

Another common problem that is encountered during field measurement is the influence of temperature variation [12]. Figure 11 shows the impact of temperature variation on tested polarization current data (recorded from TRFO17) affected by temperature variation. It is clear from Figure 11 that magnitude of the current is increasing after a specific time (at around 200s) [12], [23]. Again the recorded current does not follow a monotonically decreasing profile. Hence, CDM construction and hence performance parameter prediction is not possible. A. Baral *et al.* reported an iterative method to remove the influence of temperature variation [12], [23]. However, such a method is computationally intensive and time-consuming. In such a situation, the proposed method is useful and significantly faster. It is clear from Table IX that the values of paper conductivity and $\%tan\delta$ estimated using the suggested technique are very close to that of their measured value for TRFO17. It is worth mentioning here that both TRFO17 was later tested using DIRANA for identifying $\%pm$ value.

It is possible to predict the entire polarization current (up to 10000s) using 600s of measured data using forecasting-based methodology reported in [10]. This coupled with available CDM based methodology [18] can be used to estimate $\%pm$. However, the forecasting-based technique will require minimum 600 s of measured data that is not affected by noise or temperature transient. It is understood that data shown in Figures 10 and 11 will require proper post-processing before a forecasting-based technique [13] can be applied to such field data for the prediction of $\%pm$.

The results presented in the paper show that the performance parameters estimated by the proposed method is close to that obtained using commercial equipment like DIRANA/IDAX/ TETTEX MIDAS. This is proved by the high correlation coefficient of the fitted curve shown in Fig 7 through 9. The primary purpose of the proposed method is to perform reliable insulation diagnosis in a minimum duration without the need to post-process of recorded data.

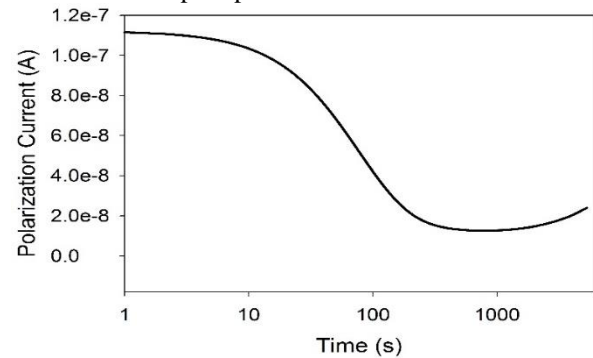

Fig. 11. Influence of temperature variation on recorded dielectric response

TABLE IX
VALUE OF PERFORMANCE PARAMETERS USING PROPOSED METHODS

Transformer Name	σ_{paper_c} (Measured (Scaled by 10^{13}))	σ_{paper_c} (Using (10)) (Scaled by 10^{13})	%error
TRFO16	5.8	5.37	7.41
TRFO17	1.3	1.21	6.92

Transformer Name	$\%tan\delta$ (Measured)	$\%tan\delta$ (Using (12))	%error
TRFO16	0.44	0.41	6.81
TRFO17	0.32	0.29	9.37

Available literature suggests that both IDAX and DIRANA are expected to take more than 30 minutes to perform insulation diagnosis [24]-[25]. As per the information provided by the utility, the time required for carrying out insulation diagnosis using IDAX 300 is observed to vary between 40 min and 70 min. While for DIRANA this time varies between 40 min and 100 min. In order to show the advantage of the proposed technique over these commercial equipment and other available technique, the time requirement for $\%pm$ estimation for TRFO17 is mentioned in Table X.

Analysis of data shown in Figure 11, using available CDM based techniques, is not straight forward. Prior to the application of any CDM based technique, the monotonic decreasing nature of polarization current needs to be ensured. In the case of TRAF017, polarization current data is first processed using [12]. Thereafter [10] is used to obtain the polarization current upto 10000s. This is followed by model formulation and analysis. In Table X, “Available PDC Technique” represents these sequences of steps [12], [10] and [18]. Application of the proposed method does not involve such complicated, computation intensive process.

TABLE X
MEASURED AND CALCULATED VALUES OF $\%pm$
FOR TRAF017

Transformer Name	$\%pm$ value	Time requirement
DIRANA	1.30	40 min
Available PDC technique	1.24	More than 600s
Proposed method	1.22	20 s

It is generally assumed that the relaxation characteristics of dipole groups in bulk oil volume dominate the initial part of the polarization current. During this time, the dipole groups in solid insulation also sense the applied external dc electric field. Hence, it can be opined that the dipole groups in solid also influence the polarization current profile, although to a lesser extent. In case a performance parameter sensitive to the relaxation process of slow-moving dipoles is identified, solid insulation condition can be assessed even from the initial portion of the polarization current. The results reported in the paper show that information regarding paper condition can indeed be obtained from the initial portion of polarization current using R_T . The proposed method requires accurate data measurement and hence requires data to be sampled at a high frequency. High sampling rate can be achieved by suitable LabVIEW programming. However, the large volume of data may increase the overall storage requirement and processing capability of the computer used for implementing the method. The method is susceptible to any high-frequency transient occurring within the first 20 seconds. However, this can be readily addressed with the help of median filtering [22].

As per the information obtained from the utilities through extensive discussions, there is no pre-determined value for the cooling time, which depends on various parameters like oil volume, rating of the transformer, operating temperature, and ambient conditions based on geophysical location of the unit. The utilities usually opt for the following procedure during field measurement of data reported in the paper: Post shutdown, tank mounted thermometer is used to monitor the top oil temperature. This temperature reading is continuously monitored as the transformer cools down. During this time, forced air and oil circulation are used to dissipate heat from the insulation. As per the information provided by the utilities, the cooling time of various transformers used in the present analysis was

different but varied between 4 to 6 hours with AFOF cooling. Once the top oil temperature reaches ambient temperature, monitoring of the oil temperature is continued for an additional 15 to 30 min before the measurement is started (with the oil pumps and fans shut down). This is done as a measure to attain thermal equilibrium as much as practicable. All offline measurements (like recording of dielectric response, analysis using IDAX, DIRANA) are initiated only when the oil temperature matches that of ambient and stays equal to it. It is to be mentioned here that the utilities found this technique of achieving thermal equilibrium less effective when AFOF is not employed during the cooling period.

Equipment like IDAX comes equipped with a built-in temperature compensation module [16], which ensures that data recorded and analyzed by IDAX remains practically unaffected by temperature variation. This further implies that the result generated by IDAX corresponds to the thermal equilibrium condition of the tested transformer. Results reported in this paper show that $\%pm$ predicted by the proposed method agree well with that obtained using IDAX. This reinforces the fact that the proposed method can detect insulation conditions using short-duration data collected from insulation under thermal equilibrium.

IX. CONCLUSION

The paper discusses a method that is capable of significantly reducing the data measurement time required to carry out insulation diagnosis. The proposed method's accuracy in predicting crucial parameters is compared with those obtained using commercial equipment. Results reported in the paper show that the proposed method could carry out insulation diagnosis with accepted accuracy. Based on the results reported in the paper, the following conclusions can be drawn:

- Polarization current data recorded for about 20 seconds can be successfully used to estimate insulation-sensitive parameters related to solid insulation.
- Without going through the insulation model formulation, the proposed method can identify insulation condition. Hence, the reported method is free from the complications associated with the parameterization of the insulation model.
- Estimated values of performance parameters using the suggested technique correlate well with that measured using commercially available equipment.
- The reduction of measurement time implies that the utility can afford to conduct multiple measurements to ensure recorded data reliability.
- As the proposed method is significantly less time-consuming, post-processing of recorded data can be avoided, which often becomes necessary when data gets affected by external noise and/or temperature variation.
- The proposed method is formulated using data collected from in-service transformers. Hence, the reported equations can be applied on data collected from other real-life power transformers without modifications.

REFERENCES

- [1] W.S. Zaengl "Dielectric Spectroscopy in Time and Frequency Domain for HV Power Equipment, Part I: Theoretical Considerations", *Electr. Insul. Mag.*, vol. 19, no. 5, pp. 5-19, Sep. 2003.
- [2] J. Liu et al., "Moisture Diagnosis of Transformer Oil-Immersed Insulation With Intelligent Technique and Frequency-Domain Spectroscopy," in *IEEE Trans. Ind. Inform.*, vol. 17, no. 7, pp. 4624-4634, July 2021, doi: 10.1109/TII.2020.3014224.
- [3] T. K. Saha, "Review of Modern Diagnostic Techniques for Assessing Insulation Condition in Aged Transformers", *IEEE Trans. Dielectr. Electr. Insul.*, vol. 10, no. 5, pp. 903-917, 2003.
- [4] N. Azis, Q. Liu and Z. D. Wang, "Ageing assessment of transformer paper insulation through post mortem analysis," in *Trans. Dielectr. Electr. Insul.*, vol. 21, no. 2, pp. 845-853, April 2014.
- [5] S. M. Gubanski et al., "Dielectric response methods for diagnostics of power transformers", *IEEE Elect. Insul. Mag.*, vol. 19, no. 3, pp. 12-18, May/June 2003.
- [6] J. Liu, T. Sun, X. Fan, Y. Zhang and B. Lai, "A Modified Simulation Model for Predicting the FDS of Transformer Oil-Paper Insulation Under Nonuniform Aging," in *IEEE Trans. Instrum. Meas.*, vol. 70, pp. 1-9, 2021.
- [7] X. Fan, J. Liu, B. Lai, Y. Zhang and C. Zhang, "FDS Measurement-Based Moisture Estimation Model for Transformer Oil-Paper Insulation Including the Aging Effect," in *IEEE Trans. Instrum. Meas.*, vol. 70, pp. 1-10, 2021.
- [8] N. Baruah, S. K. Nayak and S. K. Pratihari, "Quantitative Effect of Aging Duration on Dielectric Parameters Based on Frequency Response," in *IEEE Trans. Instrum. Meas.*, vol. 71, pp. 1-9, 2022.
- [9] T.K. Saha, P. Purkait and F. Müller, "Deriving an Equivalent Circuit of Transformers Insulation for Understanding the Dielectric Response Measurements", *IEEE Trans. Power Delivery*, vol. 20, no. 1, pp. 149-157, 2005.
- [10] D. Mishra, A.K. Pradhan, A. Baral and S. Chakravorti, "Reduction of Time Domain Insulation Response Measurement Duration for Fast and Effective Diagnosis of Power Transformer." *IEEE Trans. Dielectr. Electr. Insul.*, vol. 25, no. 5, pp. 1932-1940, Oct. 2018.
- [11] T.K. Saha and P. Purkait, "Investigations of Temperature Effects on the Dielectric Response Measurements of Transformer Oil-Paper Insulation System", *IEEE Trans. Power Delivery*, Vol. 23, No. 1, pp. 252-260, 2008.
- [12] A. Baral and S.Chakravorti, "Compensating the effect of temperature variation on dielectric response of oil-paper insulation used in power," *IEEE Trans. Dielectr. Electr. Insul.*, vol. 23, no. 4, pp. 2462 - 2474, Aug. 2016.
- [13] D. Mishra, A. Baral, S. Chakravorti, "De-noising of time-domain spectroscopy data for reliable assessment of power transformer insulation," *IET Gener. Transm. Distrib.*, Vol. 14, pp. 1500-1507, 2020.
- [14] D. Mishra, N. Haue, A. Baral, S. Chakravorti, " Estimation of paper conductivity from shortduration polarisation-depolarisation currentfor diagnosis of power transformer," *IET Sci. Meas. Technol.*, Vol. 13, no. 8, pp. 1178 - 1185, Oct. 2019.
- [15] S. Chatterjee, N. Haque, A. K. Pradhan, S. Dalai and B. Chatterjee, "Estimation of Conductivity at Reduced Time for Sensing Moisture Content of Oil-Paper Insulation," in *IEEE Sensors Journal*, vol. 20, no. 21, pp. 12999-13006, Nov. 2020.
- [16] Megger. (2019). IDAX 300/350-Insulation Diagnostic Analyzers. [Online]. Available: <https://us.megger.com/insulation-diagnostic-analyzer-idax-series>
- [17] A. Baral and S.Chakravorti, "Assessment of Non-Uniform Aging of Solid Dielectric using System Poles of a Modified Debye Model for Oil-paper Insulation of Transformers", *IEEE Trans. Dielectr. Electr. Insul.*, vol. 20, no. 5, pp. 1922-1933, Oct. 2013.
- [18] A. Baral and S. Chakravorti "Prediction of Moisture Present in Cellulosic Part of Power Transformer Insulation using Transfer Function of Modified Debye Model," *IEEE Trans. Dielectr. Electr. Insul.*, vol. 21, no. 1, pp.1368-1375, June 2014.
- [19] D. Mishra, A. Baral and S. Chakravorti, "Compensating the effect of residual dipole energy on dielectric response for effective diagnosis of power transformer insulation", *IET Sci. Meas. Technol.*, vol. 12, no. 3, pp. 314-322, 2017.
- [20] D. Mishra, A. Baral, N. Haque and S. Chakravorti, "Condition assessment of power transformer insulation using short-duration time-domain dielectric spectroscopy measurement data", *IEEE Trans. Instrum. Meas.*, vol. 69, no. 7, pp. 4404-4411, Jul. 2020.
- [21] A. K. Pradhan, B. Chatterjee and S. Chakravorti, "Estimation of dielectric dissipation factor of cellulosic parts in oil-paper insulation by frequency domain spectroscopy," in *IEEE Trans. Dielectr. Electr. Insul.*, vol. 23, no. 5, pp. 2720-2729, October 2016.
- [22] S. Chakravorti, D. Dey, and B. Chatterjee, *Recent Trends in the Condition Monitoring of Transformers*. London, U.K.: Springer, 2013.
- [23] S. Chowdhury, N. Haque, S. Chatterjee, A. K. Pradhan and S. Chakravorti, "Temperature Compensation of Frequency Domain Spectroscopy Measurement for Condition Assessment of Oil-Paper Insulation," in *IEEE Trans. Dielectr. Electr. Insul.*, vol. 29, no. 1, pp. 255-263, Feb. 2022.
- [24] DIRANA. The fastest way of moisture determination of power and instrument transformers and condition assessment of rotating machines. [Online]. <http://www.omnificolutions.co.in/uploads/DIRANA-Brochure-ENU.pdf>.
- [25] M. Koch, M. Krueger, and M. Puetter, "Advanced insulation diagnostic by dielectric spectroscopy", *TechCon Asia Pacific*, Sydney, Australia, pp. 1-13, 2009.



Deepak Mishra (S2017 - M2023)

received his Ph.D. from IIT(ISM) Dhanbad 2020. He received the prestigious POSOCO Power Systems Award (PPSA) 2022. He is presently working as an Assistant Professor in the Department of Electrical Engineering, Indian Maritime University Kolkata. His current field of interest includes condition monitoring of high voltage power equipment.



Arijit Baral (M2010 - SM2016)

received his Ph.D. degree from Jadavpur University, Kolkata, India in 2015. He is presently working as an Associate Professor in the Department of Electrical Engineering, Indian Institute of Technology (Indian School of Mines), Dhanbad, India. His current field of interest includes condition monitoring of high voltage power equipment.



Sivaji Chakravorti (M'90-SM'00)

obtained his Ph.D. degree from Jadavpur University, Kolkata, India in 1993. He is serving as a Professor in Electrical Engineering Department of Jadavpur University since 2003. He worked at the Technical University Munich as Humboldt Research Fellow in 1995-96, 1999 and 2007, respectively. He served as Development Engineer in Siemens AG in Berlin in 1998. He is a Fellow of Indian National Academy of Engineering and Distinguished Lecturer of IEEE PES. He has published more than 160 research papers. His current fields of interest are numerical field computation, condition monitoring of transformers and life-long learning techniques.