

Indian Maritime University
(A Central University, Govt of India)

Sep/Oct'25 SE

Programme Name: B Tech (NASB/NAOE)

Semester: II

Subject Code: UG13T1202/UG12T2202

Subject Name: APPLIED MECHANICS

Date: 06.09.2025

Max Marks: 70

Duration: 03 Hrs

Pass Marks: 35

General Instructions

- (i) All Sections (A, B & C) are to be attempted.
- (ii) Options, if any, are specified in respective section.

Section A – Answer ALL

Ten MCQs/Fill in the Blanks of 01 Mark each – Choose the correct answer as applicable.

1. Which among the following is not an application of Newton's third Law of motion?
 - a) A man walking on the ground
 - b) Rowing a boat
 - c) A fielder pulling his hand backward while catching a ball
 - d) Bouncing of ball

2. The resultant of two equal forces P making an angle θ , is given by
 - a) $2P \sin \frac{\theta}{2}$
 - b) $2P \cos \frac{\theta}{2}$
 - c) $2P \tan \frac{\theta}{2}$
 - d) $2P \cot \frac{\theta}{2}$

3. Moment of inertia of a circular section about an axis perpendicular to the section is
 - a) $\frac{\pi d^3}{16}$
 - b) $\frac{\pi d^3}{32}$
 - c) $\frac{\pi d^4}{32}$
 - d) $\frac{\pi d^3}{64}$

4. Centre of gravity of a thin hollow cone lies on the axis at a height of
- one-fourth of the total height above base
 - one-third of the total height above base
 - one-half of the total height above base
 - three-eighth of the total height above the base
5. A frame structure is perfect, if the number of members are ____ ($2j-3$), where j is the number of joints
- Equal to
 - Less than
 - Greater than
 - None of these
6. The principle of virtual work states that, for a body to be in equilibrium, the virtual work should be
- Any value between zero and one
 - Zero
 - Maximum
 - Minimum
7. The coefficient of restitution for inelastic bodies is
- zero
 - between zero and one
 - one
 - more than one
8. the force which acts along the radius of a circle and directed ____ the centre of the circle is known as centripetal force
- away from
 - towards
 - at the
 - none of the mentioned
9. The motion of a body in x-y plane is represented by $x=4-9t$ and $y=t^2$ where x, y are in meters. Find the magnitude of its absolute velocity at $t = 6$ sec
- 2.68 m/s
 - 5.4 km/hr
 - 10.77 m/s
 - 15 m/s

10. An object starts from rest at $x = 0$ m and $t = 0$ sec. It moves with a constant acceleration of 2 m/s^2 along the x-axis. What is its average velocity between time 1 sec and 5 sec?
- 2 m/s
 - 8 m/s
 - 6 m/s
 - 4 m/s

Section B

Five Questions of 02 Marks each – ANSWER ALL

- Write the classification of force system
- State parallel axis theorems.
- What is the principle of virtual work?
- State D`Alembert`s principle.
- State the assumptions made while studying projectile motion

Section C

Seven Questions of 10 Marks each of which any 05 questions to be answered.

16. (a) to move a boat uniformly across the river at a given speed, a resultant force $R = 520 \text{ N}$ is required. Two men are pulling it with force P and Q by means of ropes. The ropes make an angle of 30° and 40° respectively with the sides of the river as shown in the figure. Determine the force P and Q . if $\theta_1 = 30$, find the value of θ_2 such that the force in the rope Q is minimum. What is the minimum force Q ? (6 Marks)

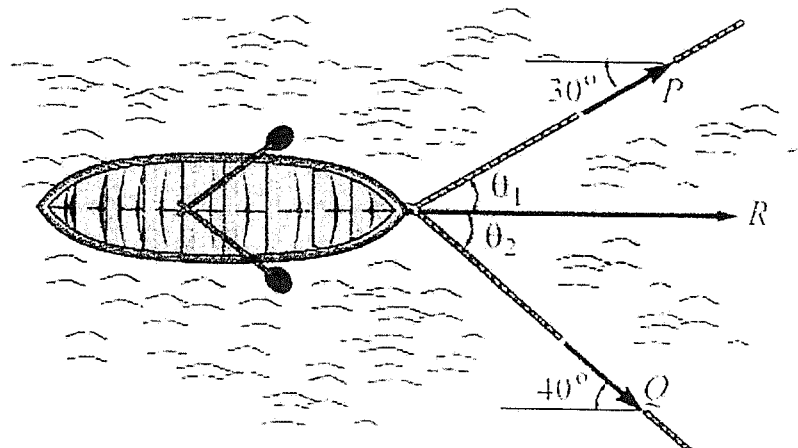

- (b) Three like parallel forces 100 N , 200 N and 300 N are acting at a point A , B and C respectively on a straight-line ABC as shown in the figure below.

The distances are $AB=30\text{cm}$ and $BC=40\text{cm}$. Find the resultant and the distance of the resultant from the point A on the line ABC. (4 marks)

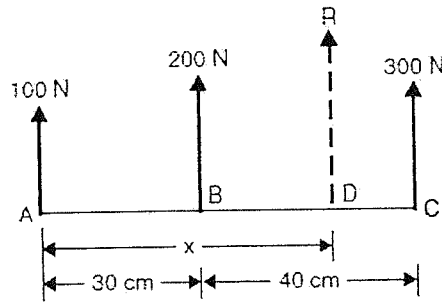

17. Three plates ABC and BCDE and DEF are welded together as shown in figure. A circle of 1.5 m diameter is cut from the composite plate. Determine the centroid of the remaining area. (10 Marks)

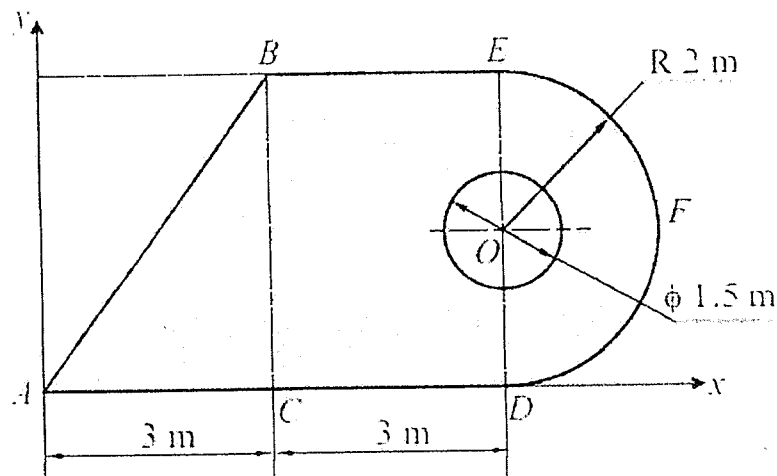

18. Find the forces in the member DF, DE, CE and EF by method of joints only for the pin jointed frame shown in the figure.

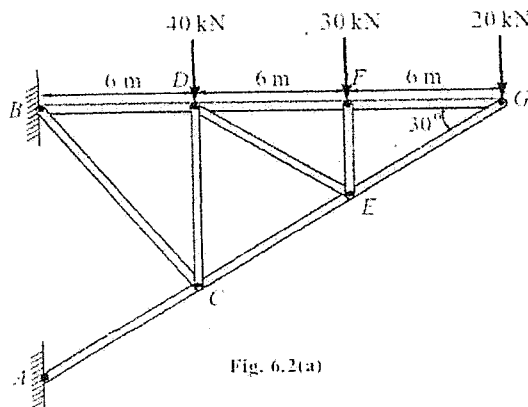
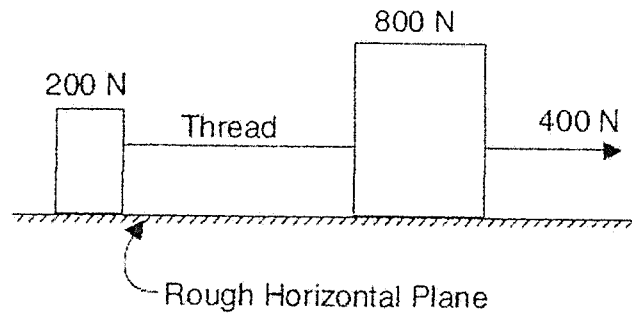

Fig. 6.2(a)

(10 Marks)

19. Two weights 800 N and 200 N are connected by a thread and move along a rough horizontal plane under the action of a force 400 N applied to the first weight of 800 N as shown in the below figure. The coefficient of friction between the sliding surfaces of the weights and the plane is 0.3. Determine the acceleration of the weights and the tension in the thread using D'Alembert's principle. (10 Marks)



20. (a) A motorist is driving his car at 90 km/hr. He observes red light 200 m ahead turns red. The traffic light is timed to remain red for 15 sec. If the motorist wishes to pass the light without stopping, find the required minimum deceleration (5 marks)
- (b) A wheel, rotating about a fixed axis at 20 rpm, is uniformly accelerated for 70 sec, during which time it makes 50 revolutions. Find (i) Angular velocity at the end of this interval and (ii) Time required for the speed to reach 100 revolutions per minute. (5 Marks)
21. a) Determine the force P required to move the block A of 5000N weight up the inclined plane. Coefficient of friction between all contact surfaces is 0.25. neglect the weight of the wedge and the wedge angle is 15°. (10 marks)

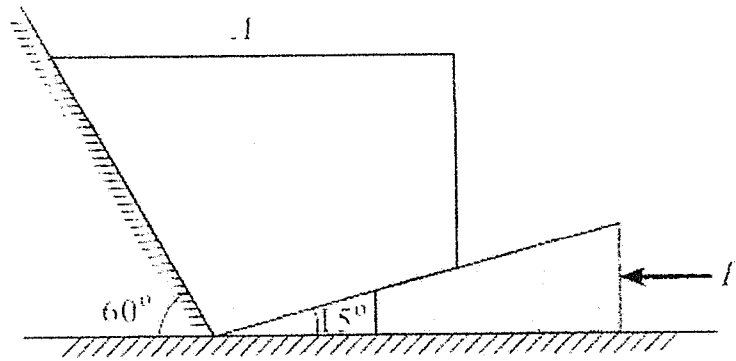

22. Find the force P for the equilibrium of mechanism in the given position shown in the figure. (10 Marks)

