

See discussions, stats, and author profiles for this publication at: <https://www.researchgate.net/publication/361785813>

# Reduction Of Engine Emission Into The Environment Through Effective Operation Of Catalytic Converter In Proportion With Pollutant

Article · July 2022

CITATIONS

0

READS

88

5 authors, including:



**Aravind Dhandapani**

Madurai Kamaraj University

20 PUBLICATIONS 11 CITATIONS

SEE PROFILE



**Thangalakshmi Prakash**

44 PUBLICATIONS 72 CITATIONS

SEE PROFILE



**Ganesh Ram**

Indian Maritime University

8 PUBLICATIONS 6 CITATIONS

SEE PROFILE

Some of the authors of this publication are also working on these related projects:



Effect of Panel Materials on the Performance of Solar Cells [View project](#)



DEVELOPMENT OF pH VALUE DETECTION SENSOR FOR WATER TO DETECT AND AUTOMATE WATER NEUTRALIZATION PROCESS [View project](#)

# Reduction Of Engine Emission Into The Environment Through Effective Operation Of Catalytic Converter In Proportion With Pollutant

D.Aravind<sup>1</sup>, V. Ganeshram<sup>2</sup>, S. Thangalakshmi<sup>3</sup>, C.P. Balaji<sup>4</sup>

<sup>1</sup>Assistant Professor, University Science Instrumentation Centre, Madurai Kamaraj University

<sup>2</sup>Lecturer- Chemistry, School of Marine Engineering and Technology, Indian Maritime University, Chennai Campus

<sup>3</sup>Faculty – Electrical, School of Marine Engineering and Technology, Indian Maritime University, Chennai Campus

<sup>4</sup>Assistant Professor, School of Marine Engineering and Technology, Indian Maritime University, Chennai Campus

## Abstract

The discharge of harmful impurities put into air which creates unwanted effects to the environments and people. Inadequate engine combustion is one of the causes for air pollution with the emission of CO, HC, NO<sub>x</sub>, SO<sub>x</sub> soon. Whenever there is an incomplete combustion takes place huge volume of CO gas is released. If the fuel includes a high Sulphur concentration, the Sulphur in the petroleum combines with the oxygen during the combustion process and releases SO<sub>2</sub>. The unburnt hydrocarbon is due to incomplete combustion and NO<sub>x</sub> (Oxides of Nitrogen) are leads to the formation of uninflamed gas in the exhaust with nitrogen. Hence, rigid norms of effluence emissions are enforced as safety measures which has made exhaust gas after-treatment systems important. In order to reduce the engine emission, the current method is the use of catalytic converter. This paper discusses an effective system for improving presentation of the catalytic converter by using an embedded controller in proportion with emission.

**Keywords:** Catalytic converter, pollutants, embedded controller, sensors, exhaust pipe, combustion.

## 1. Introduction

Diesel engines are known for their excellent performance, longevity, and consistency, as well as their cheap running costs. In addition to their extensive usage and numerous benefits, these engines play a key part in contemporary environmental pollution concerns. Internal combustion engines are regarded as one of the major sources of environmental pollution generated by exhaust fumes, as well as being liable for a lot of health issues [1].

Based on the mode of action, strategies for minimising pollutant emissions can be divided into three following classes:

a) strategies that utilise active methodologies, such as optimising the combustion process or engine manufacturing;

b) strategies that utilise passive methodologies, such as preserving and neutralising pollutant emissions around on the exhaust pipe; and

c) strategies aimed at improving fuel mix in order to reduce pollutant emissions. Whatever approach is employed, the effectiveness of the strategies for lowering pollutant emissions is dependent on the engine operating schedule [2-4].

For the purpose of effectual reduction of the emission level, a major series of methods are pertinent [16]. It improves engine design, fuel pre – combustion action and aftercombustion processes. Among these, catalytic converter originates to be a superior mode for reducing emissions. This paper presents a system to augment the effectiveness of the catalytic converter [17-18].

This work focusses to design a system that controls effectively the engine emission after combustion through effective control meant for the catalytic converter by using microcontroller in proportion with emission.

## 2. Existing catalytic converters

A device which runs the exhaust emission such as toxic gases, pollutant, emitting from an internal combustion engine into a less –toxic pollutants by using a catalyst i.e. catalyzing a redox reaction (Both loss and gain of electrons takes place at a time) [19-22].

Catalytic converters generally play a major role in the internal combustion engines fueled by either petrol or diesel including lean-burn engines [5-12].

For instance, a Triple-way catalyst has a set of three concurrent action taking place as per the following sequence:

- Oxidation process taking place in the formation of Carbon dioxide by the combination of carbon monoxide and oxygen:  
 $2\text{CO} + \text{O}_2 \rightarrow 2\text{CO}_2$
- Oxidation of unburnt hydrocarbons (HC) to  $\text{CO}_2$  and  $\text{H}_2\text{O}$ :  
 $\text{C}_x\text{H}_{2x+2} + [(3x+1)/2]\text{O}_2 \rightarrow x\text{CO}_2 + (x+1)\text{H}_2\text{O}$
- Reduction reaction of nitrogen oxides to nitrogen and oxygen:  
 $2\text{NO}_x \rightarrow x\text{O}_2 + \text{N}_2$

In existing catalytic converters, Nobel metals like platinum, palladium is generally used. For cost effectiveness, alternate material like alumina is also used [13-14]. Applications of Catalytic converters are in ceramic dome shaped, taken and impregnated into the cr,  $\text{Co}(\text{NO}_3)_2$  and  $\text{Al}_2\text{O}_3$  solution instance of wash coating method [15]. This, aids to minimize the reduction of Carbon Monoxide, Hydrocarbons emission  $\text{NO}_2$  emission [19-20].

Though numerous studies on catalytic converters for emission control have been conducted, the aspects that are incorporated in the testing and analysis make this study an evergreen issue. This study attempts to evaluate pollution control with a suggested converter for an indigenous test engine. The experiment's results are compared to those of current three-way catalysts. The following sections provide an overview of the recommended catalytic converter's operation, testing, and analysis.

## 3. Proposed system of catalytic converter

During the combustion process the exhaust gas emission level does not endure similar in all the time. The projected system functions the catalytic converter as per release of emission gas level through a shutter opening. The catalytic converter regulates the level of emissions. To make it happen, the system works in two phases: entirely open or partially open. A totally closed mode cannot be used since it will obstruct the exhaust, leading to the

pipe breaking. The projected system remains does not diverge with the types of catalytic converters.

### 3.1 System blocks in brief

Figure 1 depicts the major components of the proposed catalytic converter with an integrated controller. The system is divided into three sections: input, processing, and output, with descriptions provided below.

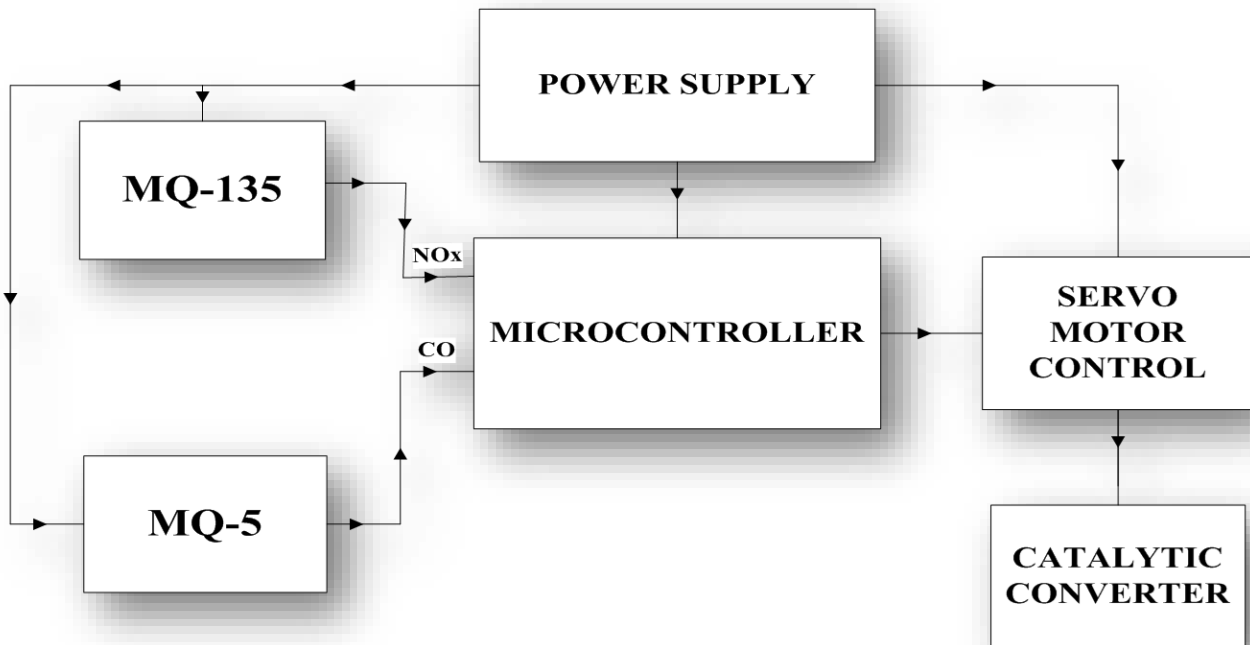

**Fig 1. General Block Diagram**

#### 3.1.1 Input Section

Sensing elements: The sensors which are capable of detecting carbon monoxide and nitrogen oxides from the exhaust pipe.

#### 3.1.2. Processing Section

Microcontroller: Programmed to detect both input and output signal to the output unit.

#### 3.1.3. Output Section

Servo Motor control: Directed to change precisely in the given angle (0-180) according to the signal received.

### 3.2 Embedded Controller details

The embedded controller plays an active part which is used to control the system. The Atmel embedded controller (AT89s8253) are utilized. High performance (low Power) CMOS 8-bit embedded controller with the size of 12K bytes of in - system programmable (ISP) flash program memory and 2K bytes of EEPROM data memory. The output and input has 32 programmers.

#### Specifications:

- Memory Chip Program Capacity of 4KB.
- Chip Data Memory (RAM) with 128 bytes
- 128 Software flags.
- Data Bus – Capacity 8 Bits.
- Address Bus having a capacity of 16-bits.
- 32 general-purpose registers, each with an 8-bit size.
- timers with 16 bits (2 will be the usual number)
- A Total of 5 interrupts (2 external & remaining are internal)
- Bit and byte addressable RAM space of 16 bytes.
- Four 8-bit ports, (short models have two 8-bit ports).
- 16-bit program counter and data pointer
- 1 microsecond instruction cycle with a crystal frequency of 12 MHz

### 3.3 Sensors

The Gas sensor MQ -135 which are used here is fit for detecting or ascertaining of various gas emissions such as Ammonia, NO<sub>x</sub>, Alcohol, aromatic hydrocarbons such as benzene, Smoke, CO<sub>2</sub>. As a gas-sensing material, the MQ-135 gas sensor employs tin oxide, which has a lower conductivity in fresh air. As a result, in an environment where polluting gases are present, the conductivity of the gas sensor rises as contaminating gas absorption increases.

This effect tends to be predominantly noticeable at an extreme temperature, and resistive heating element is present as well. Tin oxide is mainly sensitive to gases like Propane, butane and methane, but is also sensitive to other combustible gases as well. The tin oxide filament is in contact with the central heating coil H. The resistance across the heating coil does not change in the presence of fresh air; however, when a burning gas is evident, the resistance of the tin oxide strand drops, resulting in a corresponding rise in output voltage (V out), and this output voltage can be quantified to indicate the concentration of any combustible gas present.

### 3.4 Power supply block

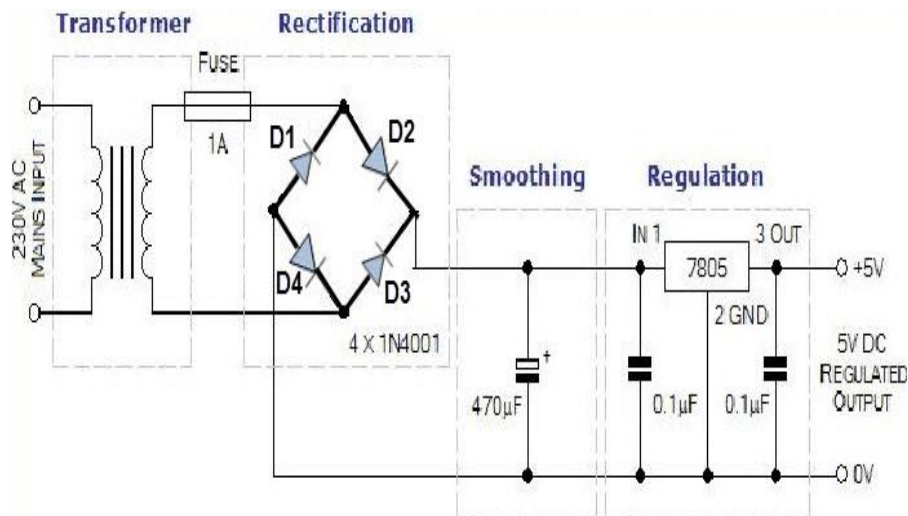

Fig 2. Path diagram for power source

It contains of a step down transformer 230/12V, which steps down the power to 12V AC. Using a Bridge rectifier, it is converted to DC. The Capacitor filter are used to remove the ripples and it is then controlled to +5V using a voltage regulator 7805 which are intended for working. The Fig.2. depicts the whole power unit configuration.

### **3.5 Servo motor**

A servomotor is a rotating actuator that enables for actual control of output and m/sec. It comprises of an effective motor connected to a position feedback sensor. It necessitates a fairly recent controller, frequently a specialised module designed expressly for use with servo motors. They are not a distinct type of motor based on their core functionality, but rather employ servomechanism to provide closed loop control with a basic open loop motor.

## **4. Working of the system**

The movement of the gas level at various exhausts is monitored, determining whether the gate is totally open or slightly open. When the gas level is pretty high, the shutter is forced to open in full; when the gas level is low, the gate is slightly open.

## **5. Test and analysis**

The locomotive was driven at speeds around 1750 rpm until a consistent temperature of 250°C was reached. It was regulated with the use of a standardized K-type thermocouple. The gas sensor was used to maintain the released emissions. Measurements in the four groups were taken by varying rpms. Each set gets a 30 second settle down period. Figures 3 and 4 show HC and CO emissions at three operating speeds: idle (1750), operational (2800), and full throttle (3800).



**Fig 3. Experimental Setup**

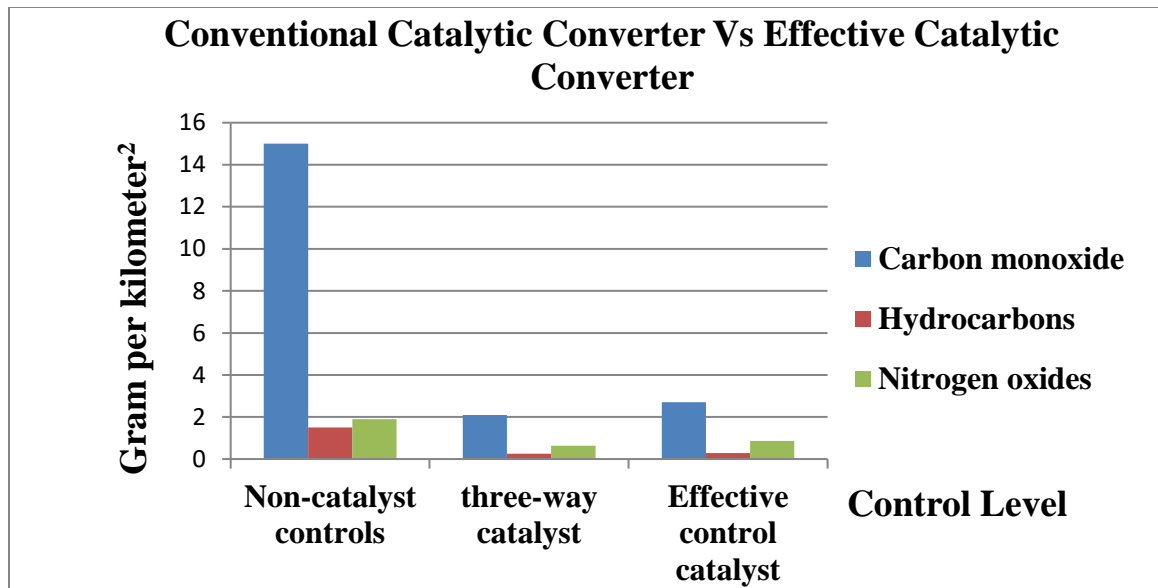

Fig 4. Analyses of conventional and effective catalytic converters

## 6. Summary and conclusion

Low budget reasons, inadequate capital of platinum group (noble) metal and otherwork restrictions of platinum group metal based catalytic converters has lead the analysis of substitute catalyst materials.

A modified catalytic converter also aids in the reduction of pollutants. When comparing the effective controlled catalytic converter and the standard catalytic converter, both stay identical.

The quality of the fuel is not taken into account in this experiment. Furthermore, if we allow for more settling time, the outcomes will be even more effective. The engine's performance degrades over time as it is used. As a result, repeating the same examination when the engine is properly used will yield better findings. When the engine is utilised continually in real-time, the efficient catalytic converter will show its superiority. Without any catalyst control, the carbon monoxide level is clearly extremely high, and the effective control catalyst demonstrates that it is a better way in emission control.

## References

- [1] Reşitoğlu, İ.A., Altinişik, K. & Keskin, A. The pollutant emissions from diesel-engine vehicles and exhaust after treatment systems. *Clean Techn Environ Policy* 17, 15–27 (2015). <https://doi.org/10.1007/s10098-014-0793-9>
- [2] Istrate, A., Bică, M., & Duinea, M. (2020, December). Compression ignitionengine–solutions for reducing pollutant emissions. In *IOP Conference Series: Materials Science and Engineering* (Vol. 997, No. 1, p. 012147). IOP Publishing.

- 
- [3] Timberlake, K. C., Timberlake, K. C., Crowe, J., Bradshaw, T., Monk, P., Lewis, R., ... & Ringe, D. (2009). *Chemistry: An introduction to General, Organic & Biological*. Pearson Benjamin Cummings.
- [4] Petrucci, R. H., Herring, F. G., & Madura, J. D. (2010). *General chemistry: principles and modern applications*. Pearson Prentice Hall.
- [5] Balakrishna, B., & Mamidala, S. (2014). Design optimization of catalytic converter to reduce particulate matter and achieve limited back pressure in diesel engine by CFD. *International Journal of current engineering and Technology*, 2, 651-658.
- [6] Katara, P. (2016). Review paper on catalytic converter for automobile exhaust emission. *Int. J. Sci. Res*, 5, 30-33.
- [7] Pardiwala, J. M., Patel, F., & Patel, S. (2011, December). Review paper on catalytic converter for automotive exhaust emission. In *International conference on current trends in technology, NUiCONE* (pp. 382-481).
- [8] Karuppusamy, P., & Senthil, D. R. (2013). Design, analysis of flow characteristics of catalytic converter and effects of back pressure on engine performance. *International journal of Research in Engineering & Advanced technology*, 1(1).
- [9] Chalapathi, S. K., Murthy, C. B., & Kumar, B. S. P. (2014). Development of automobile catalytic converter during last four decades. *Int J Res Appl Sci Eng Techn*, 2, 321-333.
- [10] Venkatesan, S. P., Uday, D. S., Hemant, B. K., Goud, K. R. K., Kumar, G. L., & Kumar, K. P. (2017, May). IC Engine emission reduction by copper oxide catalytic converter. In *IOP Conference Series: Materials Science and Engineering* (Vol. 197, No. 1, p. 012026). IOP Publishing.
- [11] Biniwale, R. B. (2001). moqik A Bawase, M MDeshmukh, NK Lahsetwar, "Production of Automotive Catalytic Converter based on Non-noble Metal Catalyst Technology A Fesible Option". *Journal of Scienific & Industrial Research*, 60.
- [12] Makwana, N. R., Amin, C. M., & Dabhi, S. K. (2013). Development and performance analysis of nickel based catalytic converter. *International Journal of Advanced Engineering Technology (IJAET)*, 4(II), 10-13.
- [13] Khurana, K. S., Rayat, K. K., Tadepalli, S., & Mishra, S. (2018). Review paper on Catalytic Converter for Automotive Exhaust Emission. *Int. J. Inform. Computing Sci.*, 5(6).
- [14] Thakur, M., & Saikhedkar, N. K. Improved and Latest Design of a Nanosized Catalytic Converter for Pollution Prevention Implemented to Four Stroke Engine with Experimental Validation by Modeling. *International Journal of Environmental Science: Development and Monitoring (IJESDM) ISSN*, (2231-1289).
- [15] Khair, M., Lemaire, J., & Fischer, S. (2000). Achieving heavy-duty diesel NO<sub>x</sub>/PM levels below the EPA 2002 standards-an integrated solution. *SAE transactions*, 7-12.
- [16] Udhayakumar, N., Mani, M., Babu, S. R., Karthikeyan, G., Samuel, K. P. J., & Karna, V. (2022). An experimental investigation on emission characteristics

- in CI engine with zinc and vanadium coated catalytic converter. *Materials Today: Proceedings*.
- [17] Patel, B. S., & Patel, K. D. (2012). A Review paper on Catalytic Converter for Automotive Exhaust Emission. *International Journal of Applied Engineering Research*, 7(11), 1-5.
- [18] Armor, J. N. (1994). Materials needs for catalysts to improve our environment. *Chemistry of materials*, 6(6), 730-738.
- [19] Karthikeyan, D., Saravanan, C. G., & Gunasekaran, E. J. (2016). Performance analysis of catalytic converters in spark ignition engine emission reduction. *International Journal of Advances in Engineering & Technology*, 9(1), 135.
- [20] Kalam, M. A., Masjuki, H. H., Redzuan, M., Mahlia, T. M. I., Fuad, M. A., Mohibah, M., ... & Yusoff, A. (2009). Development and test of a new catalytic converter for natural gas fuelled engine. *Sadhana*, 34(3), 467-481.
- [21] Kishor, K. "Control of exhaust emissions from an SI engine with metallic (Copper) coating, fuelblend and catalytic converter." *International Journal of Mechanical and Production Engineering Research and Development (IJMPERD)* 8.4 (2018): 123-132.
- [22] Mohanti, Ipsita, M. M. Krishna, and M. RAVI Chandra. "Butanol blend reduces pollutants in spark ignition engine." *International Journal of Mechanical and Production Engineering Research and Development (IJMPERD)* 10.2 (2020): 1031-1038.