

Indian Maritime University
(A Central University, Govt of India)
Supplementary Examinations – March/April 2025
Programme Name: B Tech (ME)
Semester: I
Subject Code: UG11T5106
Subject Name: BASIC ELECTRONICS

Date: 08.03.2025

Max Marks: 70

Duration: 03 Hrs

Pass Marks: 35

General Instructions

- (i) All Sections (A, B & C) are to be attempted.
- (ii) Options, if any, are specified in respective section.

Section A

Ten MCQs/Fill in the Blanks of 01 Mark each – Choose the correct answer as applicable.

1. The majority charge carriers in a p-type semiconductor is
 - (a) Holes
 - (b) Electrons
 - (c) Both a and b
 - (d) None of the above
2. If the positive terminal of the battery is connected to P-side of the diode, then it is known as
 - (a) Reverse biased
 - (b) Forward biased
 - (c) Equilibrium
 - (d) Schottky barrier
3. Which part of the output V-I characteristic of a transistor operates when it acts as an amplifier
 - (a) saturation region
 - (b) active region

(c) cut off region

(d) None of the above

4. Which of the following terminals does not belong to the MOSFET?

(a) Drain

(b) Gate

(c) Base

(d) Source

5. Which of the following statements is true about De Morgan's theorem?

a) It states that $(A+B)' = A' + B'$

b) It states that $(AB)' = A' * B'$

c) It states that $(A'B')' = AB$

d) It states that $(A+B)' = A'B'$

6. Which of the following is a universal logic gate?

a) OR

b) AND

c) XOR

d) NAND

7. Input impedance of an ideal op-amp is

a) Zero

b) Infite

c) 200 M Ω

d) 0.1 Ω

8. The expression of an EXOR gate is _____

a) $A'B+AB'$

b) $AB+A'B'$

c) $A+A.B$

d) $A'+B'$

9. What happens when the amplitude of the modulating signal is greater than the amplitude of the carrier?

a) Decay

b) Distortion

c) Amplification

d) Attenuation

10. In an ideal op-amp, which is not true?

- a) Open loop voltage gain is infinite
- b) Input resistance is infinite
- c) Slew rate is infinite
- d) CMRR is zero

Section B

Five Questions of 02 Marks each

- 11. Subtract $(0110)_2$ from $(1010)_2$ using 2's complement method?
- 12. A transistor has $\alpha=0.98$. If the emitter current of a transistor is 1mA, determine the base current and gain factor β .
- 13. Derive the relation between current gain β (Beta) and α (Alpha)
- 14. Write the ideal characteristics of an opamp
- 15. State the effect of V_{GS} on channel conductivity on N-channel JFET.

Section C

Seven Questions of 10 Marks each of which any 05 questions to be answered.

- 16. (a) Design a 1-bit magnitude comparator using logic gates. Draw the logic circuit diagram. [5]
(b) Simplify the following by K- Map $f(A,B,C,D)=\Sigma(0,1,2,4,5,8,10)$ [5]
- 17. (a) An AM wave equation is given as, $v=5(1+0.6 \sin 150t) \sin (314 \times 10^4t)$ Volts. What are the minimum and maximum amplitudes of AM Wave? What are the amplitudes and frequencies of message signal, RF carrier? [5]
(b) Draw the typical frequency response curve of a CE amplifier. How do you find out the bandwidth of amplifier? [5]
- 18. (a) What is Input offset current. How effect of Input offset current is compensated in op-amp?

(b) Expression for the output voltage V_o in terms of the input voltage V_1 and V_2 in the circuit shown in the figure, assuming operational amplifier to be ideal is $V_o = A_1 V_1 + A_2 V_2$ Values of A_1 and A_2 would be respectively

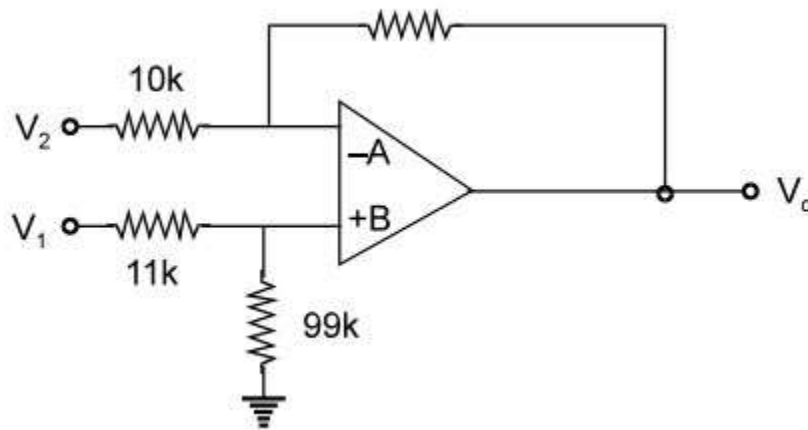

19. (a) State and prove De Morgan's theorem [5]
 (b) Draw and explain block diagram of RADAR system [5]
20. (a) Draw and explain the V-I characteristics of PN Junction diode.

(b) In figure below, it is shown that the Si Transistor with current gain $\beta=100$ is biased by Fixed Bias Method. Find I_B , R_B and R_C . (Given $V_{BE}=0.7$)

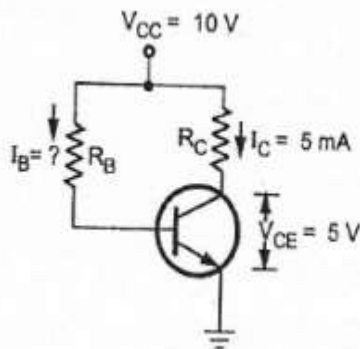

21. a) Reduce the Boolean expression: $A = XY + X(Y+Z) + Y(Y+Z)$. [5]
 b) Define the Transition Capacitance and Diffusion Capacitance. [5]
22. a) Draw the block diagram of AM super heterodyne radio receiver and state the function of each block [5]
- b) Explain with proper diagram the DC Load Line of a transistor amplifier in common emitter configuration.