

Congestion Management in Restructured Power Systems with Economic and Technical Considerations

¹S. Thangalakshmi and ²P. Valsalal

¹Department of Electrical and Electronics Engineering,
G.K.M College of Engineering and Technology, 63 Chennai, India

²Department of Electrical and Electronics Engineering,
CEG campus, Anna University, 25 Chennai, India

Abstract: Restructuring of monopolistic power systems is inevitable in this day and age to cope up with the radical growth of power demand. In developed countries restructuring is already in place while developing countries are getting accustomed to it. Above and beyond the benefits to consumers in terms of economy and quality, there are several challenges prevailing particularly in transmission while exercising deregulation. The foremost challenging task of Independent System Operator (ISO) is managing the transmission line congestion in a deregulated power system. In most of the congestion management techniques, only the economic aspects are considered. This study proposes a technique to manage congestion considering both the economical and voltage deviation aspects wherein Artificial Bee Colony (ABC) and Fish School Optimization (FSO) algorithms are used for managing congestion. These techniques are implemented in 62 bus Indian utility system and the results are compared with Particle Swarm Optimization (PSO) technique. The minimum voltage deviation for electronic industries and acceptable voltage deviation for high power applications are considered with suitable weighting factors in the objective function.

Key words: Congestion, deregulation, restructuring, ISO, Artificial Bee Colony (ABC) algorithm, Fish School Optimization (FSO)

INTRODUCTION

The electric power industry was a vertical monopolistic structure so far. There is lot of economic and methodological challenges which fortified a structural change in the power industry. This market is commonly referred as deregulated power market. Following electricity act 2003 in India, whose key features are de-licensing power generation and distribution and re-regulating transmission, open access had been introduced in transmission. To plan and coordinate the growth and expansion of the transmission network effectively, transmission is still maintained as a government owned company. In India the average per-capita electricity consumption is 883.6 kWh. The total installed capacity in India as on Dec 2015 as per Ministry of Power, Government of India is 271,722 MW out of which 37.6% of total power produced in India is contributed by private power producers after open access.

There are many entities and market players in the new electricity market. A system operator is employed for the entire system and it is delegated with the role of matching

the supply and demand. It should be a non-dependent authority without getting involved in the market competition. This system operator is known as Independent System Operator (ISO). It predicts the load, coordinates in planning the transmission capacity, acquires information about the system outages, decides the congestion management planning and prepares the system operating procedures (Sinha and Hazarika, 2001). Congestion management becomes one of the fundamental jobs of ISO in the deregulated power market since congestion challenges system security.

Congestion basically refers to overloading of transmission line when the thermal bounds and line capacities are violated. Congestion occurs mainly due to the absence of matching among generation and transmission services. The unexpected eventualities like generation outages, unexpected escalation of load demand, or equipment failure may also lead to congestion. Hence, congestion has to be relieved to ensure system security and to avoid further block-outs. There are numerous journals existing that deal with multiple methods to manage transmission line overloading in new

electricity markets. The common methods used are generation rescheduling and load shedding. Bus injection sensitivities are employed to relieve congestion of overloaded lines (Sinha and Hazarika, 2001). This method analyzes the sensitivity factor for linking real and reactive power changes with corresponding changes in line currents. The buses for rescheduling the generators and load curtailment are selected based on the Sensitivity Factor (SF). Even though this technique provides better selection of directed bus, neither the cost of generator rescheduling nor that of the load curtailment was considered to compute the modified schedules during selection of buses. The appropriate placement of TCSC in a transmission line for relieving congestion in a bilateral market model is also available in literature. It has been discussed and the results are compared with other congestion management techniques like generator rescheduling/load curtailment (Farahani and Kazemi, 2006). The effects of congestion on whole-sale market pricing and the concept of locational market price have been discussed using game theory approach. Generator rescheduling with economic sensitivity loading margin is used for managing congestion. The concept of interior point method is utilized to evaluate load margin which is a measure for voltage stability (Tang *et al.*, 2008). An appropriate Optimal Power Flow (OPF) based structure is used to manage interruptible loads in a sequential market structure of deregulated power system. Particle swarm optimization is used to fix optimal interruption loads taking into account the technical and economic aspects (Amraee *et al.*, 2005).

The evolutionary methods and algorithms play an energetic part in congestion management. Several methods have been embraced and employed for congestion management (Farahani *et al.*, 2006; Hazra and Sinha, 2007; Muneender and Kumar, 2009; Boonyaritdachochai *et al.*, 2010; Balaraman, 2010; Biswas *et al.*, 2012; Charan and Kumar, 2012). Each method has its distinct dominance based on the problem formulation, convergence time, local optima and superior quality. The various Evolutionary methods such as Particle Swarm Optimization (PSO), fuzzy PSO, Multi-objective PSO and Self-organizing Hierarchical Particle Swarm Optimization, Fitness-Distance-Ratio based Particle Swarm Optimization, Genetic Algorithm, Ant colony optimization and Differential evolution are conferred to relieve transmission line overloading in open access market.

One of the crucial methods of lightening congestion and ensuring voltage stability is assigning appropriate FACTS device in the congested lines. The type, location,

number, size and rating of FACTS devices are unlike. They depend on the severity of congestion and reason for congestion. Every writer has their own procedure and organization in using FACTS devices. The power transfer capabilities of the lines are improved by adjusting one or more parameters of selected FACTS devices and thus they help in minimizing congestion. The use of different FACTS devices such as IPFC (Interline Power Flow Controller), STATCOM (Static Synchronous COMPensator), SVC (Static VAR COMPensator), TCPST (Thyristor-Controlled Phase-Shifting Transformer), SSSC (Static Synchronous Series COMPensator) and TCSC (Thyristor-Controlled Series COMPensator) in congestion management has been presented by Zhang and Yokoyama (2006), Bai (2010), Reddy *et al.* (2012) and Likhitha *et al.* (2012).

Most of the literature had analyzed the congestion management only with economic features. Considering the economic characteristics of congestion management is not the only challenge of deregulated power systems but keeping voltage at buses after load disturbance within limits and with minimum deviation is also of concern. Even though voltages at buses are maintained within bounds, tumbling large voltage deviation guarantees high quality of customer service. In this article the objective of minimizing the cost of managing congestion ensuring minimum voltage deviation after load disturbance is achieved by the use of ABC and FSO algorithms.

Problem statement: The main problem to be addressed in deregulated electricity market is transmission line congestion. It is difficult to satisfy the entire transmission service requests at a time within a particular region. Quite a many times, the requested capacities of lines exceed the existing line capacity leading to overloading of one or more transmission lines. This situation is termed as congestion. Effective congestion management is required to serve the customers without frequent shut down. Poor management of congestion leads to further problems like extra outages, low system security and instability. Often, congestion influences the electricity price. Hence, an OPF should be formed taking into account both the technical and economic constraints.

Load behaviour is recognized as one of the main driving forces of the voltage collapse. The voltage deviation issue gets more pronounced due to heavy loading in this environment. Hence an OPF is formulated accounting the voltage quality criteria in addition to minimize the operating cost. The objective function with minimum voltage deviation factor is shown below.

Objective function: The objective function can be designed with cost constraints and voltage quality constraints. The cost constraint aims to utilize those generators for rescheduling which offer lowest bids and to reduce the total rescheduling cost. The voltage quality constraint aims to minimize voltage deviation at bus after load disturbance. This can be mathematically expressed as: where f_{cost} , $f_{vdeviation}$ are the proposed fitness function for cost and voltage deviation respectively. They are characterized as:

$$f_{cost} = \frac{\sum_{i=1}^{N_g} P_i}{\sum_{i=1}^{N_g} [(C_{max\ price} - C_{price_i}) P_i + 1]}$$

$$f_{vdeviation} = \left[\frac{e^{(\sum_{i=1}^k V_{diff}^z)}}{\sum_{n=1}^m (L_{nmax} - L_n)} \right]$$

Where:

- $C_{max\ price}$ = Max price among the bidders
- C_{price_i} = Price bid submitted by bidder i
- P_i = Power generated at generator i
- L_n = Utilized line capacity
- L_{nmax} = Maximum line capacity
- V_{diff} = Difference from reference voltage
- N_g = Number of generators
- m = Number of transmission lines
- k = Number of buses (all values in fitness function are normalized)

Subject to the following conditions:

- Total power generated = total load+total losses
- Power output of participating generator is less than that of maximum rated capacity generator
- Line utilization is less than the line capacity
- Voltage variation is minimal and is within the limits

The values of maximum price, minimum price, price bid submitted, real power, line utilized capacity and the difference from reference voltages are normalized using min-max normalization technique. Normalization is usually done for adding values with different units.

$\beta = 1 - \alpha$ where α is the weighting factor of cost fitness function and a β is the weighting factor of voltage fitness function.

Experiments were carried out using ABC and FSO for finding the optimal value of α and β . The optimal value obtained was 0.3 for most economic condition. Other values are assigned based on industrial requirement but the value may be chosen by the consumer in the deregulated environment.

The power flow is carried out for 62 bus Indian utility test system which is shown in Fig. 1 through the given constraints. The line losses, utilized line capacity, bus

information with voltage and phase angle limits, generator and load data are acquired and investigated from the OPF. The particulars of devices of test system are listed:

- Number of buses: 62 with a voltage limit between 0.9 and 1.1 pu and phase angle limit between 45 ± 45 degrees
- Number of generators: 19 with real power capacity of 2909 MW and reactive power capacity of 710.6 MVAR
- Number of Loads: 33 with real power capacity of 2909 MW and reactive power capacity of 1,270 MVAR
- Total Number of Lines: 89
- Number of Lines with transformer: 11 with tap setting ranging from 0.953-1.0155

The net MW loss and MVAR loss is 72.55 and 33.38 respectively under normal conditions. Three different congestion cases are taken for illustration. The congestion is deliberately created in transmission line for analysis by increasing the load at one or more buses. The proposed algorithms are applied on the test system to realize the objective and the results are compared with PSO technique after running the power flow.

Creating congestion: The congestion is made intentionally by raising the load at one or more buses. The lines are identified as congested lines if the line capacity exceeds the specified capacity of the line. The following 3 cases of congestion are considered and analyzed in this study:

Case 1: Single Line Congestion (SLC) is created by increasing the load at bus 38-12%. Line 37-38 is identified as overloaded line as the MVA limit is violated.

Case 2: Two Line Congestion (2LC) is created by increasing the load at bus 11-19%. Lines 10-11 and 14-16 are identified as overloaded lines as the respective MVA limit is violated.

Case 3: Three Line Congestion (3LC) is created by increasing the load at bus 55-38%. Lines 10-11, 14-16 and 55-58 are identified as overloaded lines as the respective MVA limit is violated.

Choosing the value of weighting factors (α and β): The values of α and β are assigned in the range of 0-1 depending on the weightage to be given for cost and voltage quality required. In a deregulated environment α and β values can be chosen by the customer. For example

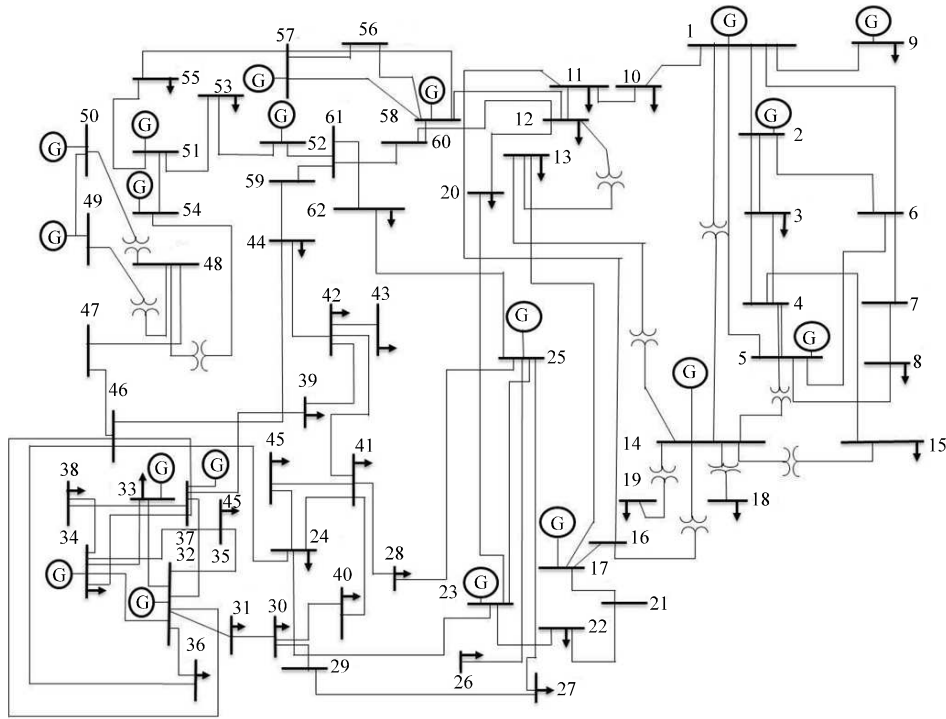

Fig. 1: IEEE 30 bus system

electronic industries that deal with minimum value of voltage may choose high value of α because even an infinitesimal change in voltage largely influences the quality of the product whereas industries that deal with high rating machineries may choose high value of β because minuscule change in the voltage does not influence the quality of the product. Three different values for α and β are assumed for analysis for all cases as follows:

- $\alpha = \beta = 0.5$ (equal weightage given for economic and technical consideration)
- $\alpha = 0.7; \beta = 0.3$ (more weightage given for economic consideration compared to technical consideration)
- $\alpha = 0.3; \beta = 0.7$ (more weightage given for technical consideration compared to economic consideration)

A summary of particle swarm optimization and proposed optimization techniques is presented for understanding.

MATERIALS AND METHODS

Particle Swarm Optimization: PSO algorithm integrates local search methods and global search methods, trying to poise exploration and manipulation. In PSO:

- Each single solution = Bird in the search space = particle

- Fitness values of all particles = Fitness judged by the fitness function to be optimized.
- Direction of the flying of particles = Particles' velocities
- Every particle in PSO can be characterized by its current speed/velocity, the best optimist position of every individual and the supreme optimist position of the neighbour

There are two terminologies such as P best (previous best) and G best (global (or) neighborhood best) with relevance to PSO.

P_{best} is the best solution of the individual particle and G_{best} is the best value, got so far by any particle in the crowd. The concept of particle swarm optimization algorithm and its applications are presented (Bai, 2010). There are five following basic steps in PSO:

- Initialization of population in space
- Assessing fitness of separate particle
- Altering the velocities based using P_{best} and G_{best}
- Terminating on certain condition
- Repeating step 2

The PSO parameters settings are as follows:

- Initial population: 30
- Number of iterations = 1,000

- C1 and C2 are constants that define the local and the global search parameter of PSO (Bai, 2010)
- They are assigned as $C1 = C2 = 0.5$
- Termination criteria = (No. of iterations-1,000] (or) objective function ≤ 0.01

Artificial Bee Colony algorithm: Artificial Bee Colony (ABC) is a population based swarm intelligence algorithm. It pretends the foraging behavior of a swarm of bees. It is derivative of honeybee colony model. A model of searching behavior of a honeybee colony comprises of three essential mechanisms viz. food sources, employed hunters and unemployed hunters.

Food sources: A honey bee assesses several stuffs of the food source in order to choose a food source. Its closeness to the hive, quality of nectar, fruitfulness of the energy and approach to extract this energy are the few properties considered.

Employed hunters: An employed hunter is involved with a specific food source which is being currently consumed. Information about this particular source and parts with it is carried and informed to other bees in the hive. The distance, the route and the viability of food source are some of the included information.

Unemployed hunters: They look for a food source to share. They may be scout searching the environment randomly or they obtain information from employed bees to find a food source.

The data interchange amongst bees is the most vibrant incidence in the formation of collective facts. Some portions are same in all hives. The furthest essential part of the hive with respect to information transaction is the dancing area. Quality of food sources is communicated amongst bees happens in the dancing area. The associated dance is called waggle dance:

- In ABC algorithm
- Potential result to the optimization problem is equal to the point of a food source
- Quality (fitness) of the related result is equal to the nectar quantity of a food source
- Number of results in the population is equal to the number of employed hunters

The idea of artificial bee colony algorithm is defined with relevant illustrations and its performance is compared with other renowned optimization algorithms (Karaboga And Akay, 2009). The detailed algorithm for ABC optimization is shown below:

- Set the population size
- Estimate fitness function
- Select best sites and neighborhood
- Recruit bees for selected best sites
- Select best bees from each site
- Remaining bees perform random search to evaluate their fitness function
- Form new population
- If convergence occurred, stop the searching. If not, repeat step

The parameters assigned for this algorithm are:

- Initial food source = 30
- Initial number of workers bees = 30
- Number of scout bees = 15

Fish school optimization algorithm: Fernandes *et al.* (2009) proposed the FSO in which each fish represents a solution. Its success through search is designated by its weight. FSO is performed with the following four operations:

- Individual movement which is required for local exploration
- Feeding for updating the fish weights. This indicates the degree of success or failure during the search
- Collective-instinctive movement for ensuring the apt direction of fish movement
- Collective-volitive movement for controlling the search granularity

The above operations are executed for each fish during all iterations. Fish weight is evaluated according to the following equation:

$$W_i(t+1) = w_i(t) + \frac{\Delta f_i}{\max(|\Delta f|)}$$

Where:

- $W_i(t)$ = The weight of the *i*th fish
- Δf_i = Represents the difference of fitness function amidst new position and current fish position
- $\max(|\Delta f|)$ = Represents the value of the greatest fitness variation among all fishes

RESULTS AND DISCUSSION

Congestion is created by raising the MW load at few buses to such a value that some of the lines are loaded beyond its thermal limit and line capacity. The congested lines are recognized from their transfer capability from the

Table 1: Economic information for 62 bus system

Bus No.	Genco No.	Bid prices		
		a_i (\$/MW ² hr)	b_i (\$/MWhr)	c_i (\$/hr)
17	6	0.0055	4.0	90
32	9	0.0085	6.0	55
51	15	0.0065	4.7	80
58	19	0.0080	5.5	90

Table 2: Overload data and line limit

Case	Overloaded lines	Line limit (MVA)	Actual MVA	Overload (%)
SLC	37-38	100	107.4	7.4
2LC	10-11	100	105.5	5.5
3LC	14-16	100	102.9	2.9
	10-11	100	102.0	2.0
	14-16	100	105.1	5.1
	55-58	900	98.9	9.8

Table 3: Power losses-congestion management

Case	Rescheduling			
	Real power losses (MW)		Reactive power losses (MVAR)	
	Before	After	Before	After
SLC	76.0	63.6	-15.6	-78.0
2LC	74.6	73.3	-22.6	-29.5
3LC	74.8	73.1	-21.2	-30.7

power flow results. Three cases of congestion are examined as explained in previous section of this study. 62 bus Indian utility system is used for testing the congested cases. The 62 bus system consists of 19 generators, 33 load points and 89 transmission lines as shown in Fig. 1. The designed programs are applied to the 62 bus Indian utility system as a sample model of power system.

The economic information of participating generators, overload, line limit data and the power losses are tabulated in Table 1-3, respectively. The coefficients a_i , b_i and c_i in Table 1 represent the bid prices of Gencos in deregulated market. They are represented with the units of \$/MW²-hr, \$/MW-hr and S/hr respectively.

Case A; Single Line Congestion (SLC): It is created by raising the load at bus 38-186MW. Line 37-38 is identified as congested line as the MVA limit is violated. Generator 9 (G9) connected at bus 32 is rescheduled to relieve congestion without disturbing voltage stability.

Case B; Two Line Congestion (2LC): It is formed by increasing the load at bus 11-191 MW. The MVA limits of lines 10-11 and 14-16 are exceeded beyond their capacity and hence they are identified as overloaded lines. Generator 19 (G19) connected at bus 58 is rescheduled to dismiss congestion ensuring voltage stability.

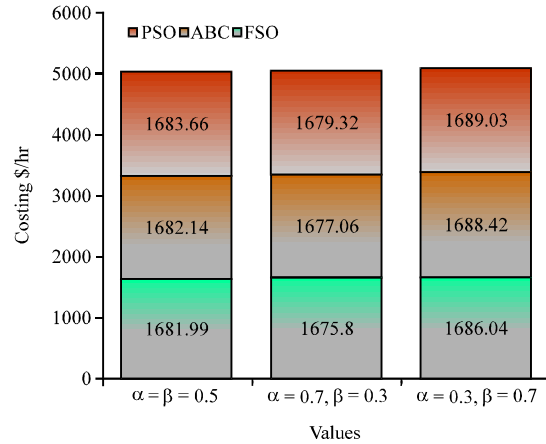

Fig. 2: Graphical results: rescheduling cost of generation case A (SLC)

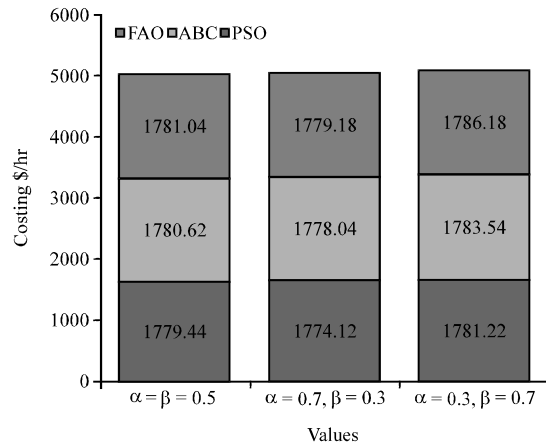

Fig. 3: Graphical results: rescheduling cost of generation case B (2LC)

Case C; Three Line Congestion (3LC): It is produced by increasing the load at bus 55-130 MW. Lines 10-11, 14-16 and 55-58 are identified as overloaded lines as the respective MVA limit is exceeded the capacity. Generator 6 (G6) connected at bus 17 and Generator 15 (G15) connected at bus 51 are rescheduled to alleviate congestion guaranteeing line stability.

Proposed techniques are applied to find the total cost of generation after relieving congestion with assumed values of α and β .

The cost of rescheduling after relieving congestion for considered cases is shown from Fig. 2-4. The following observations are made from the figures: the cost of rescheduling is least when $\alpha = 0.7$ and relatively high when $\alpha = 0.3$ from case A-C. Also, the minimum cost is obtained with FSO technique for all cases. The rescheduling cost keeps on increasing with reduced value of β and vice-versa.

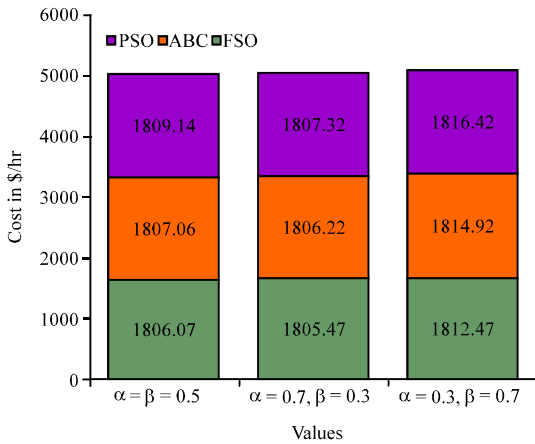

Fig. 4: Graphical results: rescheduling cost of generation case C (3LC)

With $\alpha = \beta = 0.5$, the cost reduction by FSO is 0.16% and by ABC is 0.08% while comparing PSO for three line congestion. The same is 0.09% by FSO and 0.023% by ABC for two line congestion. Also, for single line congestion the cost is reduced by 0.1% by FSO and 0.09% by ABC when compared to PSO.

With $\alpha = 0.7$ and $\beta = 0.3$, the reduction in cost by FSO is 0.1% and by ABC is 0.06% while comparing PSO for three line congestion. The same is 0.28% by FSO and 0.064% by ABC for two line congestion. Also, for single line con-gestion the cost is reduced by 0.21% by FSO and 0.13% by ABC when compared to PSO.

With $\alpha = 0.3$ and $\beta = 0.7$, the reduction in cost by FSO is 0.22% and by ABC is 0.083% while comparing PSO for three line congestion. The same is 0.28% by FSO and 0.148% by ABC for two line congestion. Also, for single line congestion the cost is reduced by 0.18% with FSO and 0.04% with ABC when compared to PSO.

The average cost of saving by FSO is 0.18% and annual cost of saving is around 16%. The average cost of saving by ABC is 0.08% and approximate annual cost of saving is 7%.

Voltage stability refers to the ability of a power system to maintain steady voltages at all buses in the system after being subjected to a disturbance (Likhitha *et al.*, 2012). The deviation in bus voltages after the load disturbance is very minimum by the proposed algorithm compared to PSO. The graphs showing the bus voltages after relieving congestion is shown from Fig. 5-7 when β is 0.7 and α is 0.3. It is observed that ABC and FSO are giving almost the same voltages. Hence, the

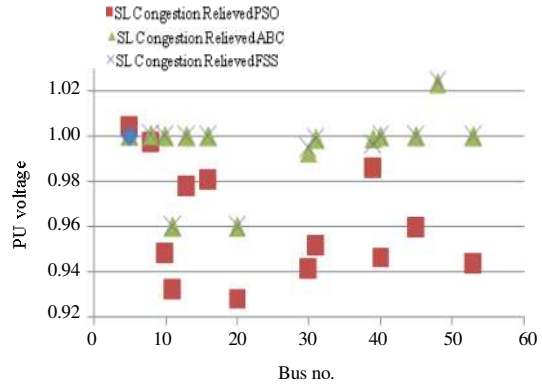

Fig. 5: Graphical results; bus voltages-case A (SLC)

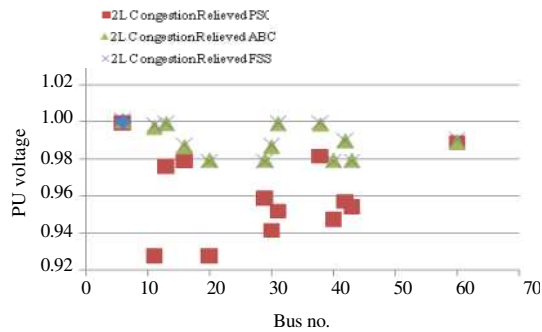

Fig. 6: Graphical results; bus voltages-case B (2LC)

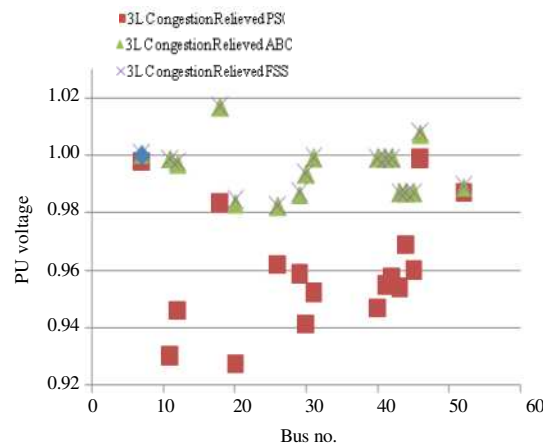

Fig. 7: Graphical result; bus voltages-case C (3LC)

buses at which there is a minor change in the results of ABC and FSO alone are considered for drawing graph. In some of the literatures FSO is referred as FSS which is Fish School Search optimization. It is evident from Fig. 5-7 that the proposed algorithm maintains the bus stability compared to PSO at all buses considered.

CONCLUSION

In this paper, congestion management with economical and technical considerations is proposed. Artificial Bee Colony Algorithm and Fish School Algorithm are employed to find the cost of rescheduling with different economic and voltage quality constraints. ABC and FSO techniques were used to arrive at an optimal value for weightage factors that govern the cost and voltage quality. The congested cases are created by overloading some of the lines till the thermal limits are violated. The rescheduling cost is computed using proposed techniques and the results are compared with Particle Swarm Optimization. The comprehensive simulation on 62 bus Indian utility system and the test results infer that the cost of rescheduling using FSO is less in all cases compared to other methods considered. Also it is evident that the maximum cost saving is obtained when α is high for the entire test cases meanwhile a minimum voltage deviation is achieved when α is assigned with a high value. It is concluded that there is always a compromise between cost and quality but still there is an optimum value at which the minimum voltage deviation is ensured with nominal cost of rescheduling.

REFERENCES

- Amraee, T., B. Mozafari, A.M. Ranjbar, A.R. Shirani and A. Mozafari, 2005. An interruptible load management method with considering voltage stability in a restructured power system: An OPF approach. Proceedings of the 18th International Conference and Exhibition on Electricity Distribution, June 6-9, Turin, Italy, pp: 1-5.
- Bai, Q., 2010. Analysis of particle swarm optimization algorithm. *Comput. Inf. Sci.*, 3: 180-180.
- Balaraman, S., 2010. Application of differential evolution for congestion management in power system. *Mod. Appl. Sci.*, 4: 33-42.
- Biswas, S., K.K. Mandal and N. Chakraborty, 2012. Modified differential evolution based multi-objective congestion management in deregulatory power environment. *Int. J. Elec. Elect. Comput. Eng.*, 1: 93-97.
- Boonyaritdachochai, P., C. Boonchuay and W. Ongsakul, 2010. Optimal congestion management in an electricity market using particle swarm optimization with time-varying acceleration coefficients. *Comput. Math. Appl.*, 60: 1068-1077.
- Farahani, V.Z. and A. Kazemi, 2006. Comparing two ways of congestion management in bilateral based power market. Proceedings of the Conference on GCC, March 20-22, 2006, IEEE, Manama, Bahrain, ISBN: 978-0-7803-9590-9, pp: 1-8.
- Farahani, V.Z., A. Kazemi and A.B. Majd, 2006. Congestion management in bilateral based power market by FACTS devices and load curtailments. Proceedings of the 2006 IEEE Conference on Power India, April 10-12, 2006, IEEE, New Delhi, India, ISBN: 0-7803-9525-5, pp: 6-8.
- Hazra, J. and A.K. Sinha, 2007. Congestion management using multiobjective particle swarm optimization. *IEEE. Transac. Power Syst.*, 22: 1726-1734.
- Karaboga, D. and B. Akay, 2009. A comparative study of artificial bee colony algorithm. *Appl. Math. Comput.*, 214: 108-132.
- Likhitha, B., J.S. Rao and J. Amarnath, 2012. Sensitivity approach for the effective location of TCSC in a deregulated electricity market. *IOSR. J. Eng.*, 2: 2250-3021.
- Muneender, E. and D.V. Kumar, 2009. Optimal real and reactive power dispatch for zonal congestion management problem for multi congestion case using Adaptive Fuzzy PSO. Proceedings of the IEEE Region 10 Conference on TENCN, January 23-26, 2009, IEEE, Singapore, ISBN: 978-1-4244-4546-2, pp: 1-6.
- Reddy, M.B., Y.P. Obulesh and S.S. Raju, 2012. Analysis and simulation of series facts devices to minimize transmission loss and generation cost. *Int. J. Adv. Eng. Technol.*, 2: 463-473.
- Sekhar, C. and A. Kumar, 2012. Congestion management in pool electricity markets with loadability limits. *J. Eng. Technol.*, 2: 24-31.
- Sinha, A.K. and D. Hazarika, 2001. A fast algorithm for line over load alleviation in a power system. *J. Inst. Eng. Electr. Eng. Div.*, 82: 64-71.
- Tang, Y., B. Ma and Y. Li, 2008. A new congestion management method considering voltage stability under electric market. Proceedings of the 3rd International Conference on Electric Utility Deregulation and Restructuring and Power Technologies, April 6-9, 2008, IEEE, Nanjing, China, ISBN: 978-7-900714-13-8, pp: 567-571.
- Zhang, J. and A. Yokoyama, 2006. Optimal power flow control for congestion management by interline power flow controller (IPFC). Proceedings of the International Conference on Power System Technology, October 22-26, 2006, IEEE, Chongqing, China, ISBN: 1-4244-0110-0, pp: 1-6.